

*ASSEMBLY INSTRUCTIONS*  
*COASTER FINE FURNITURE*



*Fine Furniture for every stage of life*

**224031KW (B1-B3)**  
***California King Bed***

# ITEM: 224031KW (B1-B3)



## ASSEMBLY INSTRUCTIONS

### ASSEMBLY TIPS:

1. Remove hardware from box and sort by size.
2. Please check to see that all hardware and parts are present prior to start of assembly.
3. Please follow attached instruction in the same sequence as numbered to assure fast and easy assembly.



### WARNING !

1. Don't attempt to repair or modify parts that are broken or defective. Please contact the store immediately.
2. This product is for home use only and not intended for commercial establishment.



ASSEMBLY TIME

25 MINUTES

## PARTS IDENTIFICATION

### B1 (BOX 1)

A	HEADBOARD PANEL		1PC
B	HEADBOARD BOTTOM RAIL		1PC
C	RIGHT HEADBOARD LEG		1PC
D	LEFT HEADBOARD LEG		1PC

### B2 (BOX 2)

E	FOOTBOARD PANEL		1PC
F	FOOTBOARD LEG		2PCS

### B3 (BOX 3)

G	BED RAIL		2PCS
H	BED SLAT		4PCS
I	BED SLAT SUPPORT WITH LEVELER		8PCS
HB	224031KW (B1) *FROM BOX 1 HEADBOARD COMPLETE		1PC
FB	224031KW (B2) *FROM BOX 2 FOOTBOARD		1PC

# ITEM: 224031KW (B1-B3)



## ASSEMBLY INSTRUCTIONS

### ASSEMBLY TIPS:

1. Remove hardware from box and sort by size.
2. Please check to see that all hardware and parts are present prior to start of assembly.
3. Please follow attached instruction in the same sequence as numbered to assure fast and easy assembly.











### WARNING !

1. Don't attempt to repair or modify parts that are broken or defective. Please contact the store immediately.
2. This product is for home use only and not intended for commercial establishment.

## HARDWARE IDENTIFICATION



### Z-B1 (BOX 1) - HARDWARE PACK IS LOCATED IN 224031KW (B1)

1	<b>BIG BOLT</b> (M8 x 50mm - BLK)		6PCS	5	<b>SMALL BOLT</b> (M6 x 40mm - BLK)		2PCS
2	<b>BIG LOCK WASHER</b> (M8 - BLK)		6PCS	6	<b>SMALL LOCK WASHER</b> (M6 - BLK)		2PCS
3	<b>BIG FLAT WASHER</b> (M8 - BLK)		6PCS	7	<b>SMALL FLAT WASHER</b> (M6 - BLK)		2PCS
4	<b>BIG ALLEN WRENCH</b> (M5 x 65mm - BLK)		1PC	8	<b>SMALL ALLEN WRENCH</b> (M4 x 65mm - BLK)		1PC

### Z-B2 (BOX 2) - HARDWARE PACK IS LOCATED IN 224031KW (B2)

9	<b>THREADED BOLT</b> (3/8" x 2 3/4" - SR)		2PCS
---	--	---	------

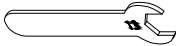
### Z-B3 (BOX 3) - HARDWARE PACK IS LOCATED IN 224031KW (B3)

10	<b>THREADED BOLT</b> (M8 x 100mm - RBW)		8PCS	12	<b>WRENCH</b> (M13 - SR)		1PC
11	<b>HEX NUT</b> (M8 x 15mm - RBW)		8PCS	13	<b>PAN HEAD SCREW</b> (4 x 1 1/4" - SR)		8PCS

### NOTE :

Philips head screw driver is required in the assembly process; however, manufacturer does not provide this item.

ITEM: **224031KW (B1-B3)**  
**ASSEMBLY INSTRUCTIONS**

**STEP 1**

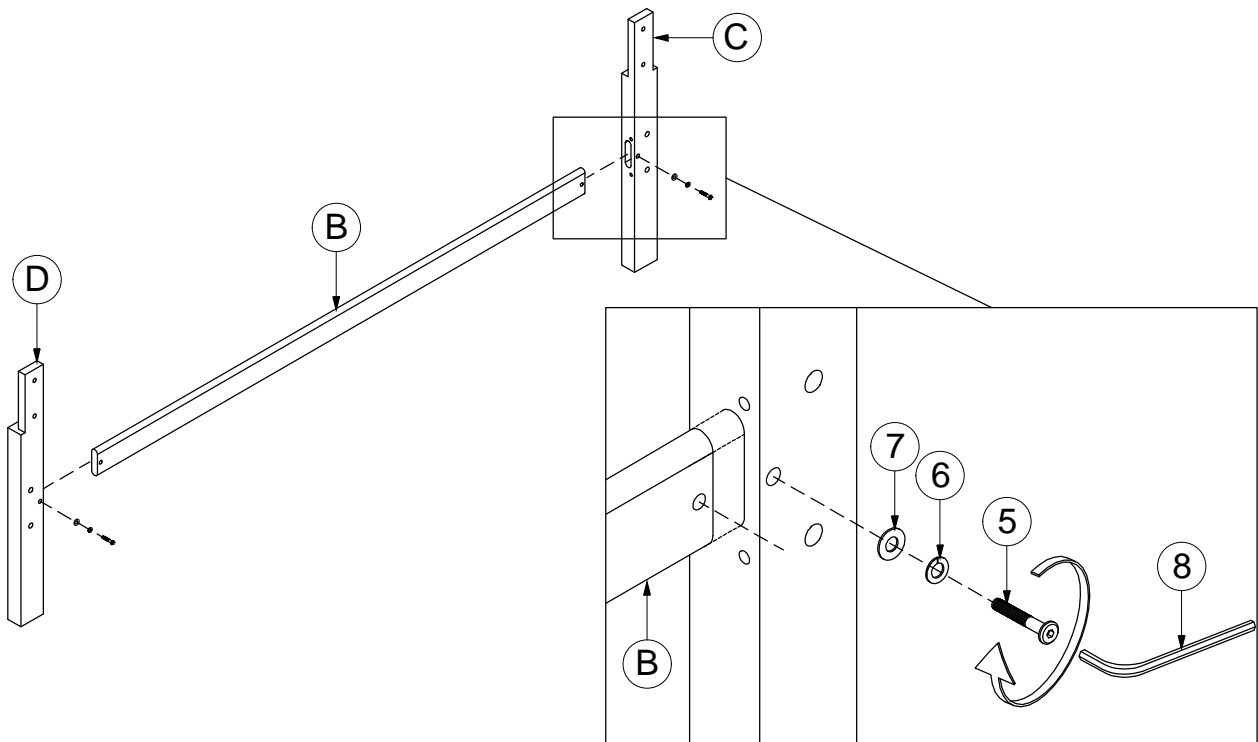

**STEP 2**

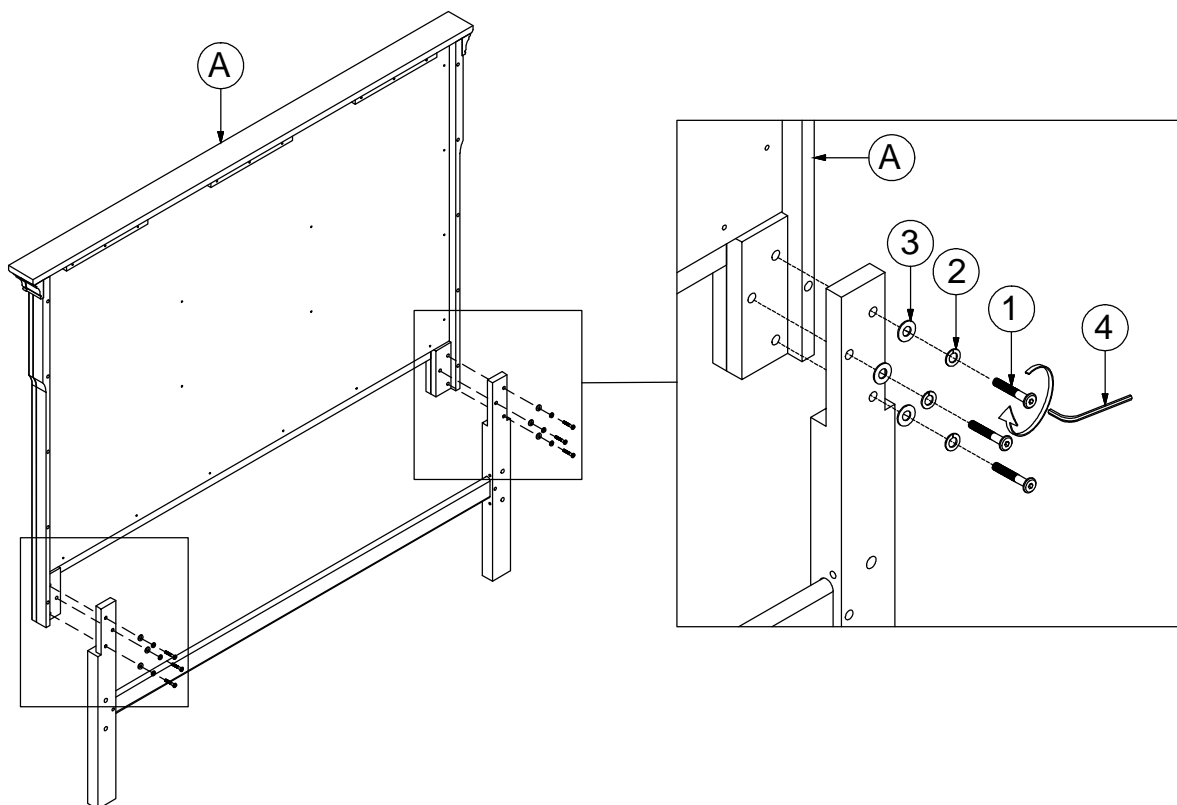

# ITEM: 224031KW (B1-B3)

## ASSEMBLY INSTRUCTIONS

### STEP 3

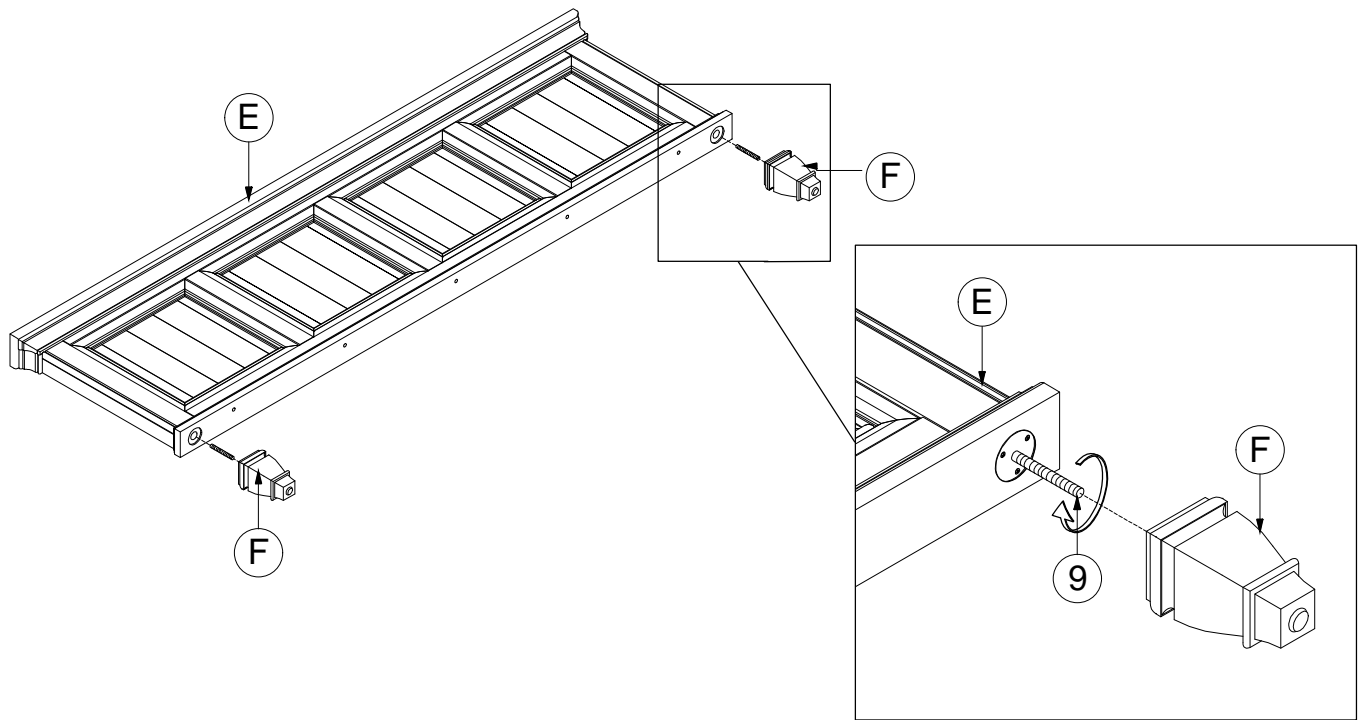

### STEP 4

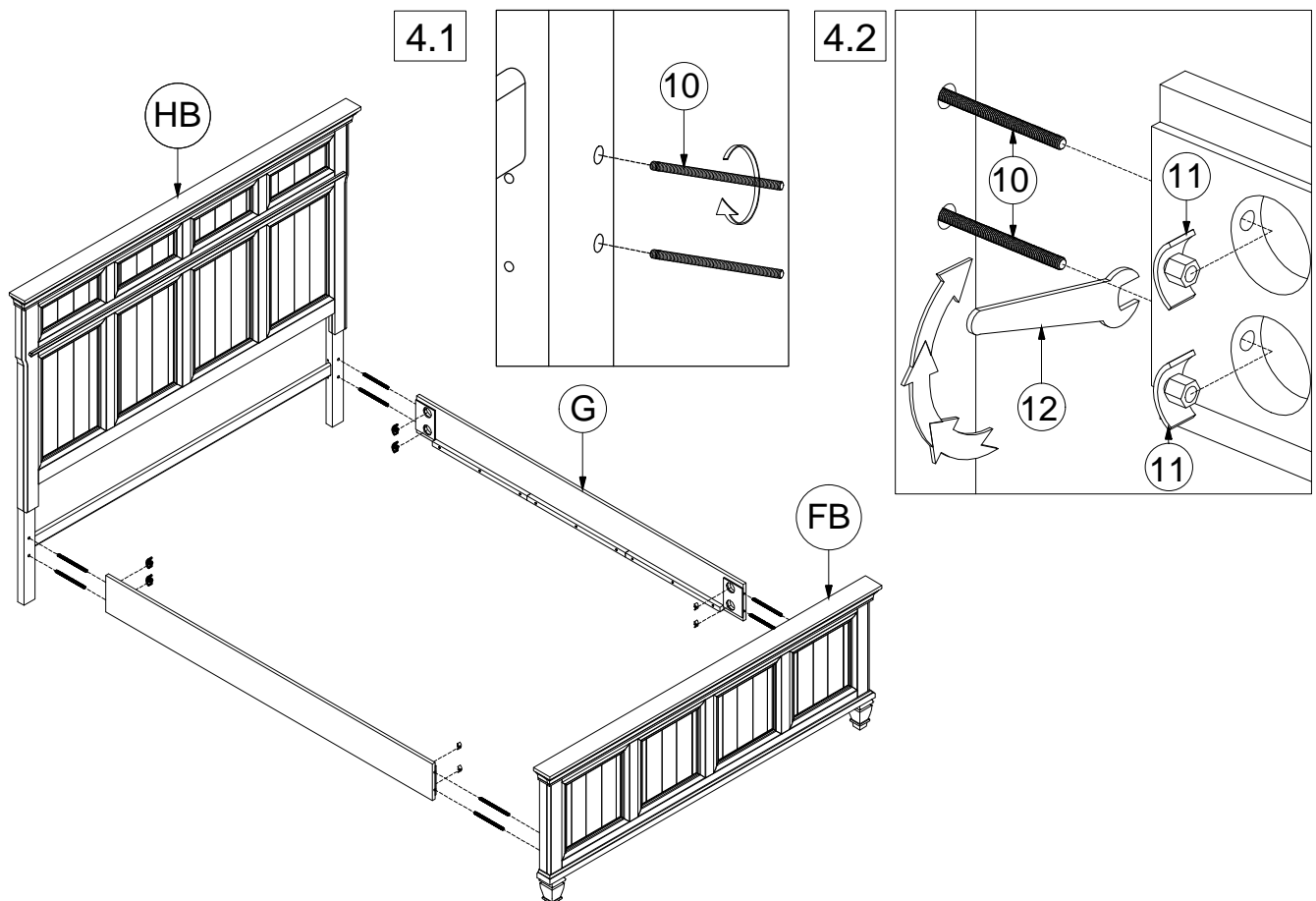

# ITEM: 224031KW (B1-B3)

## ASSEMBLY INSTRUCTIONS

### STEP 5

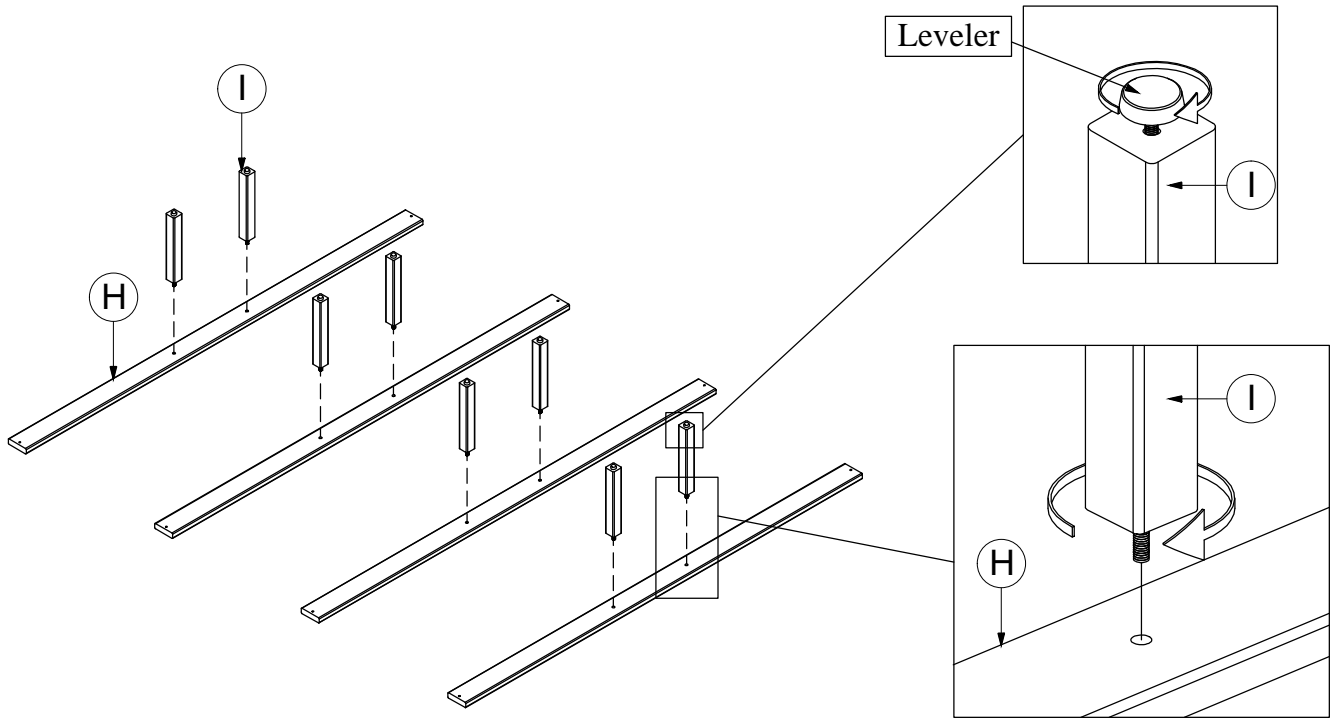

### STEP 6

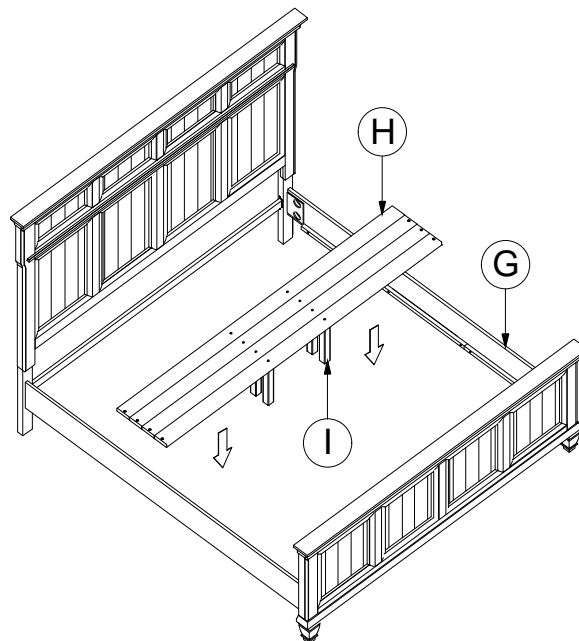

ITEM: **224031KW (B1-B3)**  
**ASSEMBLY INSTRUCTIONS**



**STEP 7**

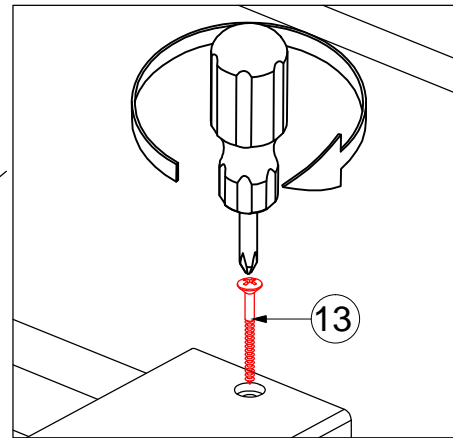
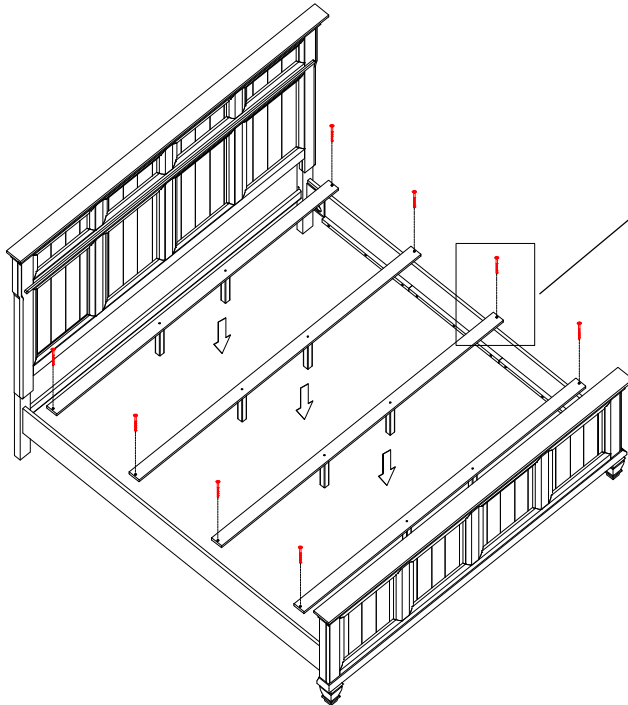

**STEP 8**  
**COMPLETE**

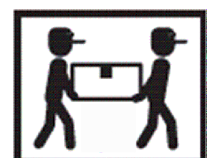
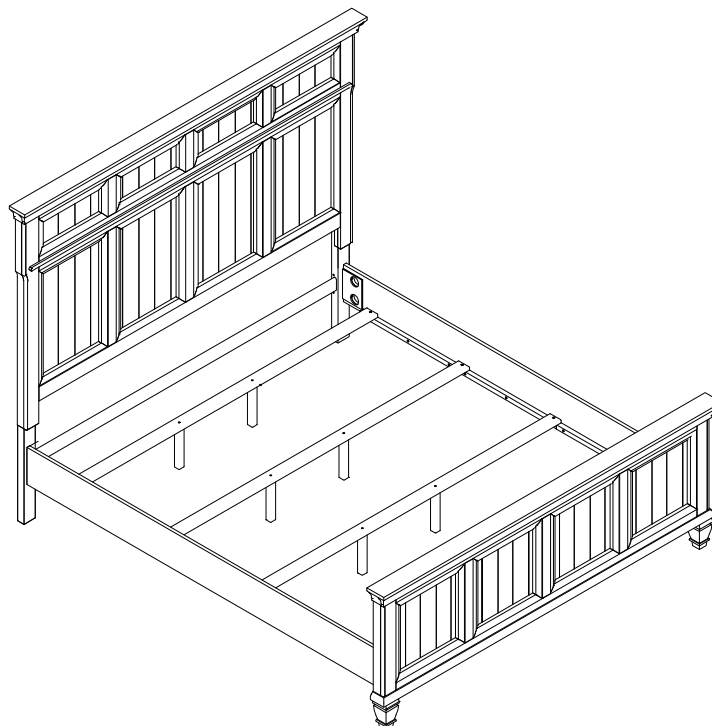

# ITEM: 224031KW (B1-B3)



Inner Size : 73.00"W X 85.00"D

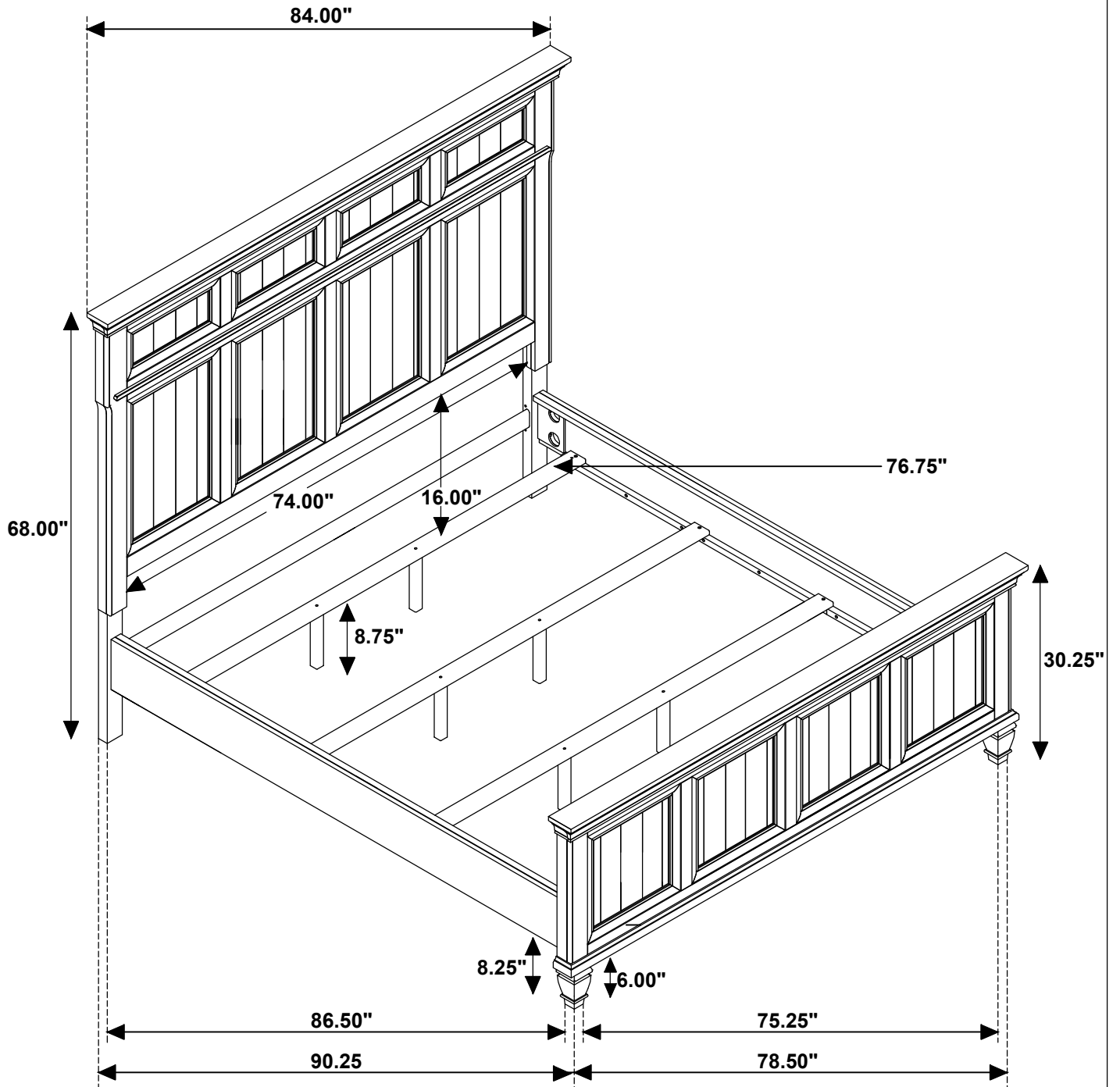

Note : Dimension tolerance  $\pm 5\%$