

**Furniture of America®**

# Assembly Instructions

For more information contact our team: [service.ec@foagroup.com](mailto:service.ec@foagroup.com)

## CM-AC6165

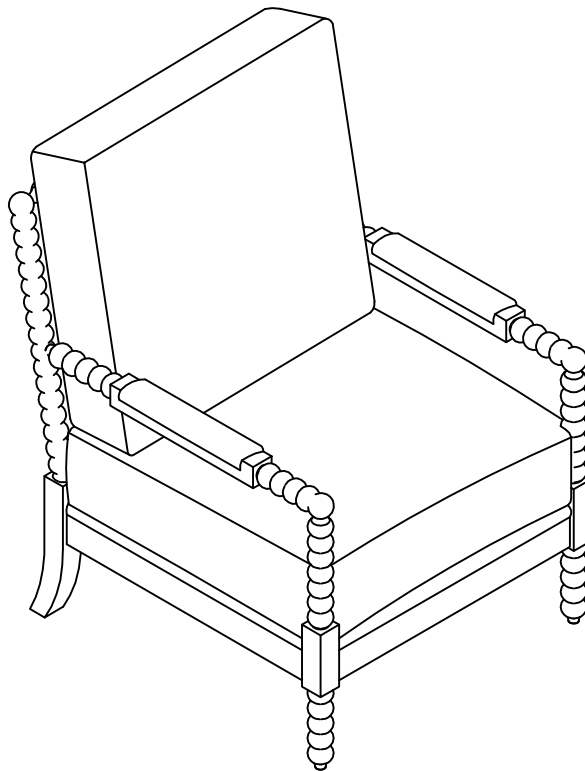

### ASSEMBLY RATING

The Assembly Rating is a 5-point system that shows the degree of effort needed in assembling a specific product (with 1 being easy and 5 being difficult). For some products, two persons are recommended.

### Tools Required For Assembly:

Allen Wrench

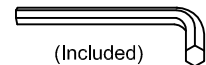

EASY



DIFFICULT

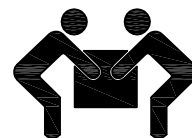

**2 PERSONS RECOMMENDED**

# ASSEMBLY & CARE ADVICE

FOR YOUR FURNITURE TO LAST, CORRECT ASSEMBLY AND PROPER MAINTENANCE ARE NECESSARY. PLEASE FOLLOW THE INFORMATION PROVIDED BELOW TO FULLY ENJOY YOUR FURNITURE.

## BASIC ASSEMBLY TECHNIQUES



When lock or spring washer is used in an assembly, please make sure the lock or spring washer is placed between the larger flat washer and the head of the screw or bolt.



Position each part correctly and insert screws or bolts into their respective holes by hand tighten or using the proper hand tool. Only tighten when step is completed or when instructed to do so.

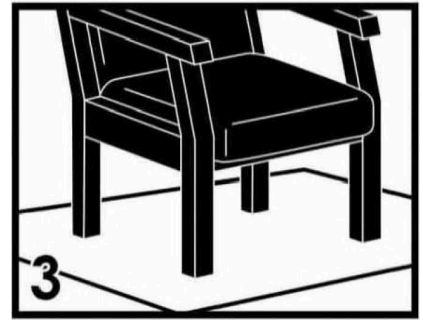

Use cardboard or carpet area when assembling furniture to prevent scratches. Make sure the furniture rests on a flat and level surface with each leg evenly touching the floor.



Some furniture comes with height adjustment knobs underneath each leg. To lower or to raise each leg, you need to turn clockwise or counterclockwise, respectively.

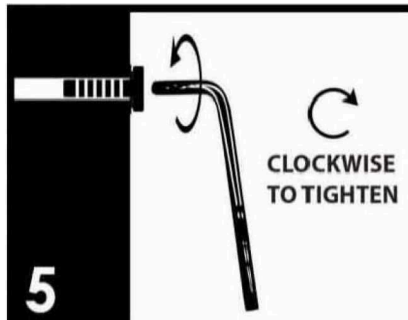

Make sure all parts are properly aligned, then use the appropriate hand tool to completely tighten the bolts or screws. Do not use power tools and do not overtighten.

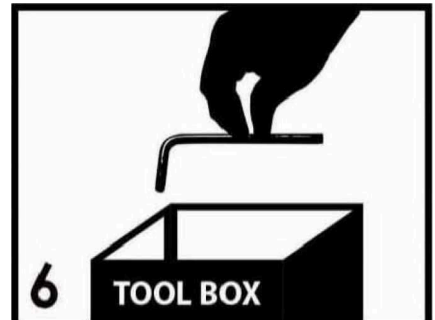

Save the instructions and store the Allen wrench or any supplied tool for later maintenance. After two weeks, check and tighten any loose hardware and repeat again every six months thereafter.

IT IS THE USER'S RESPONSIBILITY TO MAINTAIN THE FURNITURE. THE HARDWARE MAY LOOSEN OVER TIME AND MAY CAUSE THE FURNITURE TO BE WOBBLY AND UNABLE TO SUPPORT ITS INTENDED WEIGHT CAPACITY. THIS MAY LEAD TO COLLAPSE AND MAY CAUSE SERIOUS INJURY.

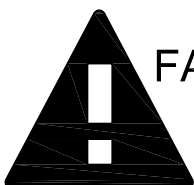

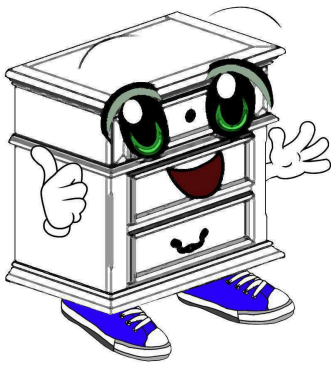

**FAILURE TO FOLLOW THE GUIDELINES ABOVE MAY RESULT IN INJURY AND/OR PROPERTY DAMAGE.**







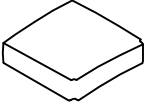
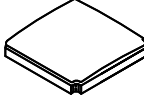





Before you begin, please read Page 2 of "Assembly and Care Advice".

And remember, do not tighten until each step is completed or instructed.

### Parts List

-  #1 x 1pc  
Chair Back
-  #2 x 1pc  
Seat Cushion
-  #3 x 1pc  
Seat Frame
-  #4 x 1pc  
Left Arm
-  #5 x 1pc  
Right Arm

### Hardware List

-  #A x 1pc  
Allen Wrench 5/16"
-  #B x 4pcs  
Bolt Ø5/16"\*3-1/4"
-  #C x 4pcs  
Bolt Ø5/16"\*2-1/4"
-  #D x 2pcs  
Bolt Ø5/16"\*1-3/4"
-  #E x 10pcs  
Lock Washer-Big Ø5/16"
-  #F x 10pcs  
Flat Washer-Big Ø5/16"\*22mm
-  #G x 1pc  
Allen Wrench 1/4"
-  #H x 2pcs  
Bolt Ø1/4"\*1-3/4"
-  #I x 2pcs  
Lock Washer-Big Ø1/4"
-  #J x 2pcs  
Wood CAP 14\*7mm
-  #K x 2pcs  
Wood Dowel 10\*30mm



1) Insert wood dowels (#K) to the holes of the seat frame (#3), then align the seat frame (#3) to the holes of the chair back (#1).

#B x 4pcs  
#D x 2pcs  
#E x 4pcs  
#F x 4pcs

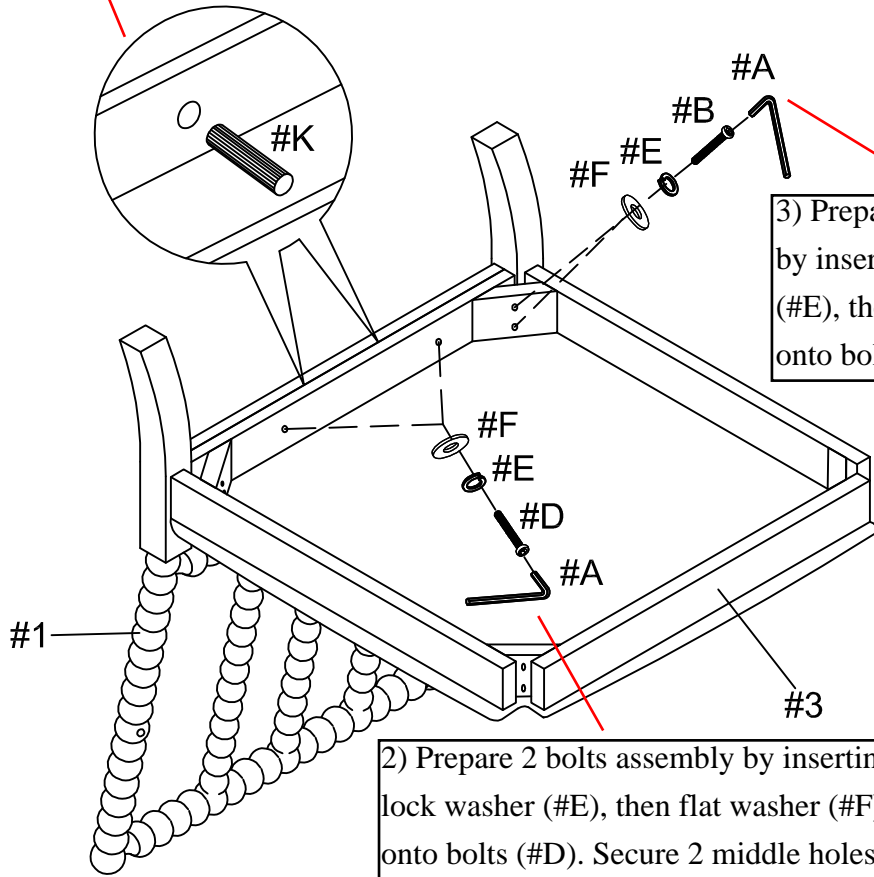

3) Prepare 4 bolts assembly by inserting lock washer (#E), then flat washer (#F) onto bolts (#B).

2) Prepare 2 bolts assembly by inserting lock washer (#E), then flat washer (#F) onto bolts (#D). Secure 2 middle holes with bolts (#D).



#H x 1pc  
#I x 1pc  
#J x 1pc

Prepare 1 bolts assembly by inserting washer (#I) onto bolts (#H). Align Left arm (#4) to the left side holes of the chair. Secure with bolts (#H) and cap the hole with a wood cap (#J).

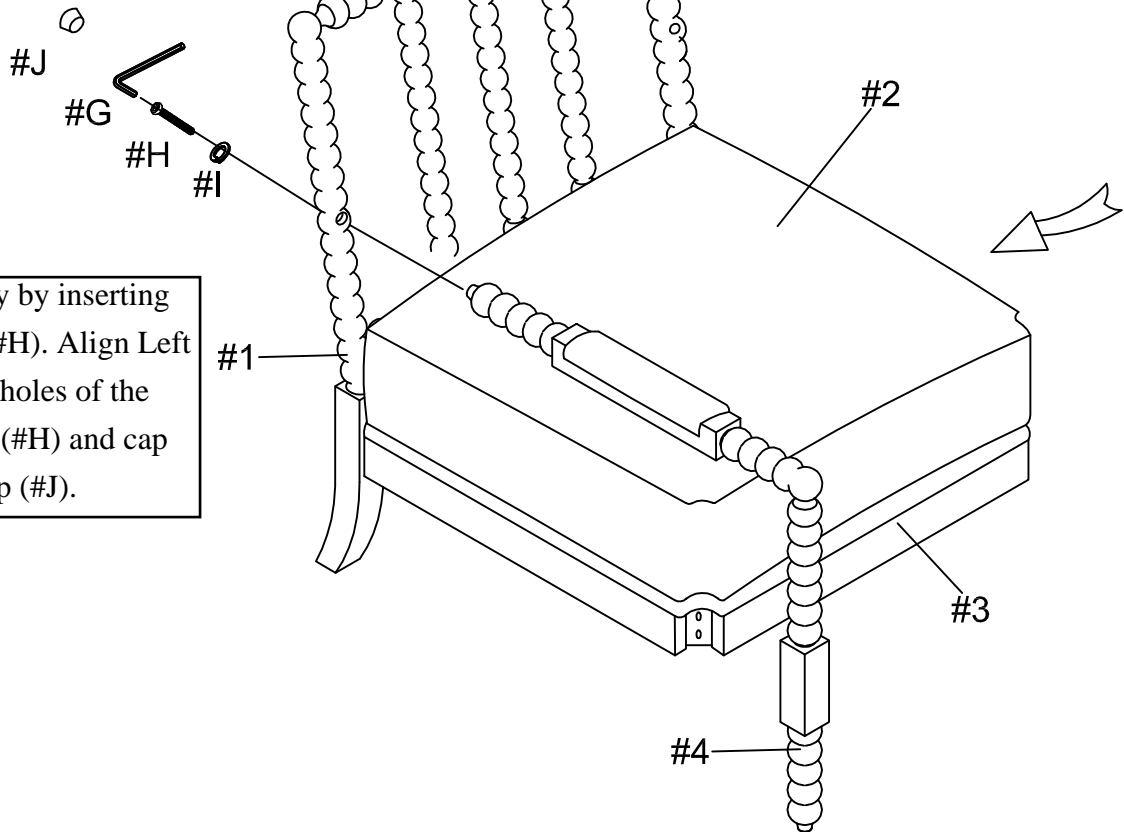



#3

Prepare 2 bolts assembly by inserting lock washer (#E), then flat washer (#F) onto bolts (#C). Secure holes of left arm (#4) to seat frame (#3) with bolts (#C).

- #C x 2pcs
- #E x 2pcs
- #F x 2pcs

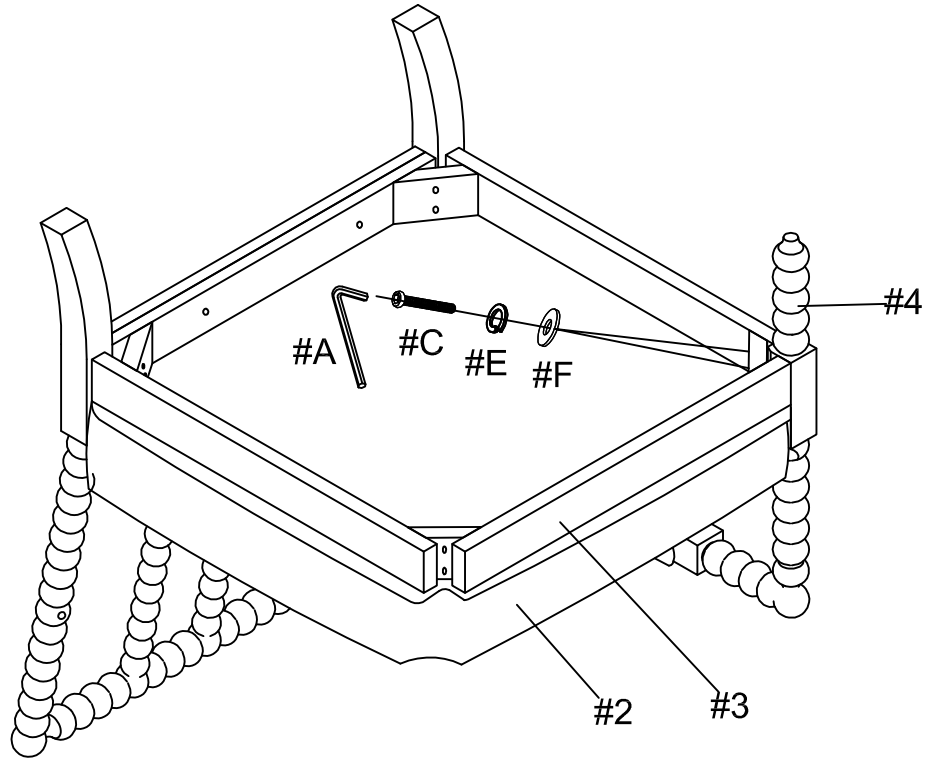

#4

Align right arm (#5) to the holes of the chair back (#1) and seat frame (#3). Secure right arm (#5) to chair back with bolts (#H) that contains washer (#I).

- #C x 2pcs
- #E x 2pcs
- #F x 2pcs
- #H x 1pc
- #I x 1pc

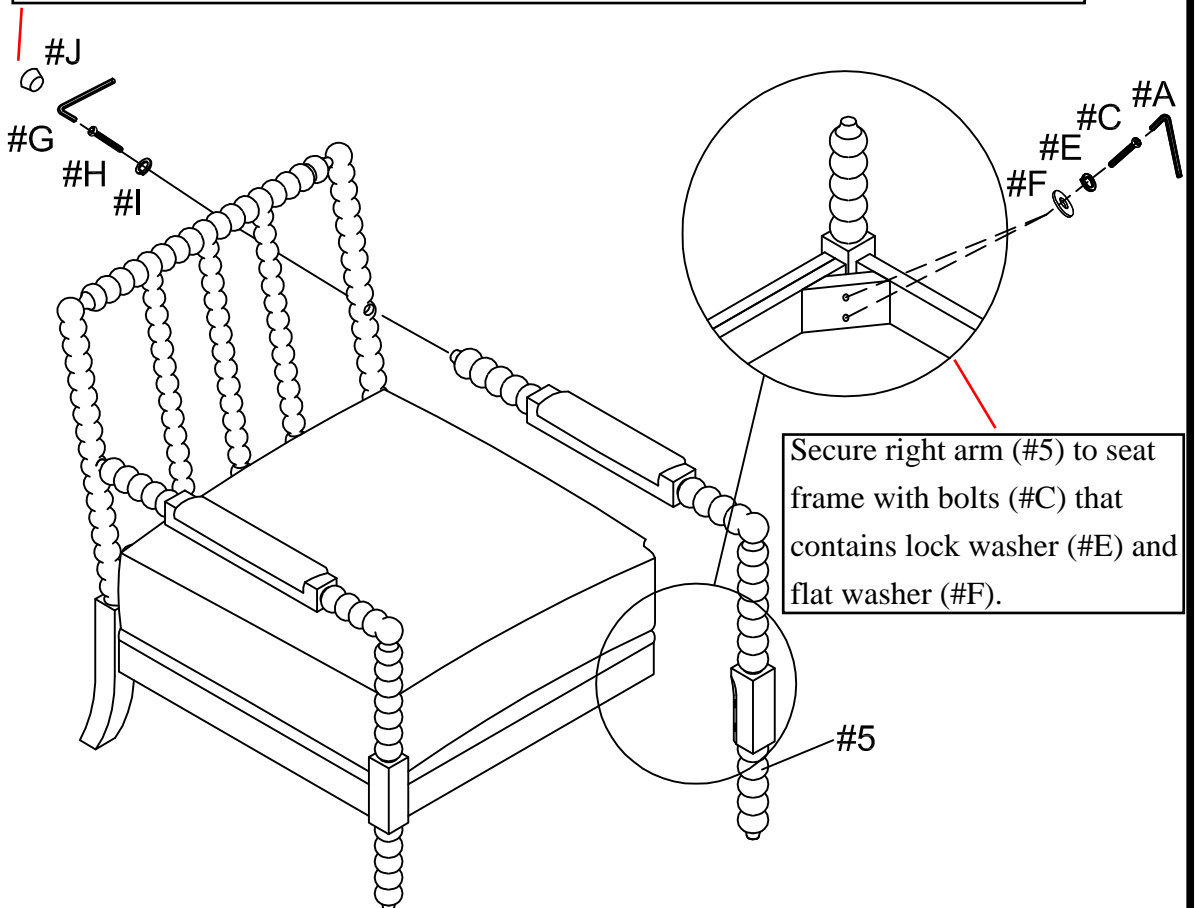

Secure right arm (#5) to seat frame with bolts (#C) that contains lock washer (#E) and flat washer (#F).



Assembly Completed

