



Furniture of America[®]

E-Commerce by Enitial Lab

ASSEMBLY INSTRUCTIONS

MODEL #

CM1739 (VN)

Questions?

GIVE US CALL: 1-888-980-5122
MON-FRI 8:30AM - 5:30PM (PST)

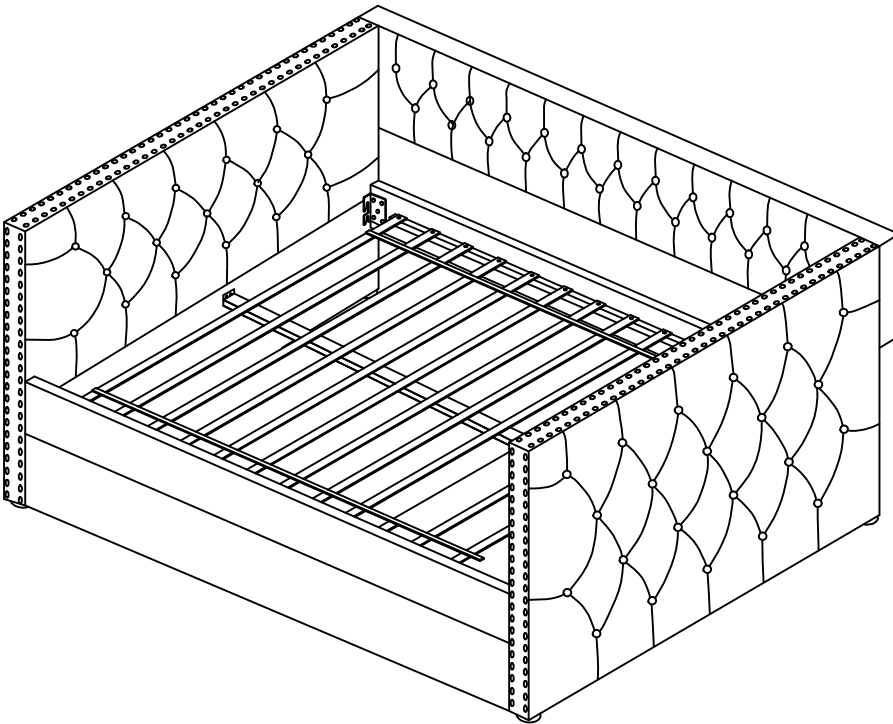

TOOLS REQUIRED



Allen Wrench

(Included)



**Phillips
Screwdriver**

(Not Included)



**3 - People
Recommended**

ASSEMBLY RATING



EASY —————> DIFFICULT

The Assembly Rating is a 5-point system showing the level of effort needed to assemble a specific product.





FOA Intro

Thank you for your purchase!

We hope you enjoy this new addition to your home for many years to come.

Our commitment to providing quality products does not simply end when you purchase our product. We fully stand behind our products from start to finish. Our customer service department is available Monday – Friday 8:30 AM – 5:30 PM Pacific and can help with assembly questions as well as, if necessary, replacing damaged or missing parts. To help expedite our service, please have these assembly instructions readily available, along with your order receipt.

 **Consumer Hotline**
Toll-Free 1-888-980-5122

 **Monday to Friday**
8:30AM- 5:30PM (PST)

 **WEBSITE**
www.foagroup.com

 **E-MAIL**
cs.ec@foagroup.com

    foagroup

 FurnitureOfAmerica

CHECK BEFORE STARTING

Are you missing anything?

Double-check all parts, hardware and accessories listed on Page 6 are accounted for.

Check out our Quick Tips!

We recommend reviewing the pre-assembly handouts. Even experts need a refresher now and then!

Should we send any replacements?

Are there any irregularities or flaws in the parts? We can send replacements!

Prep Time!

Please review the assembly instructions and all diagrams prior to assembling. Arrange parts as recommended on Page 7 and group identical hardware together to make assembling easier.

PRE ASSEMBLY INTRODUCTION

We understand building ready-to-assemble furniture can be a challenging experience for some. To help avoid confusion, we have provided some helpful tips that may speed up the process.



Teamwork

ALWAYS have at least two people to help with transporting and assembling the product to avoid potential injury and/or damage.

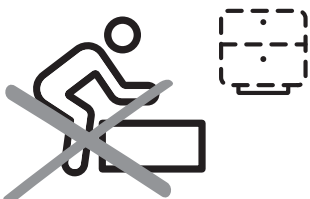

Suitable Location

Assembling near the area of the intended location is highly recommended.



Sufficient Space

Make sure you have enough space to move around during the assembly.



Avoid Scratches

Use cardboard, blankets or a carpeted area while assembling furniture to prevent scratches.



Flat Surface

Make sure the furniture rests on a flat and level surface with each leg evenly touching the floor.

ASSEMBLY AND CARE ADVICE



FAILURE TO FOLLOW THE GUIDELINES BELOW MAY RESULT IN INJURY AND/OR PROPERTY DAMAGE.



Position each part correctly and insert screws or bolts into their respective holes.

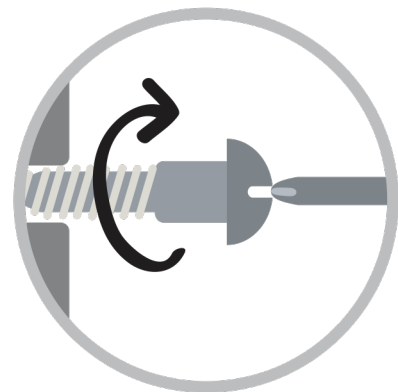

Turn clockwise to tighten and only tighten when step is completed or when instructed to do so.



Use the appropriate hand tools or power tools for assembly. Select steps, such as tightening screws and/or bolts, may require hand tools to avoid causing damage during assembly.



Save the instructions and store any supplied tools for later maintenance.

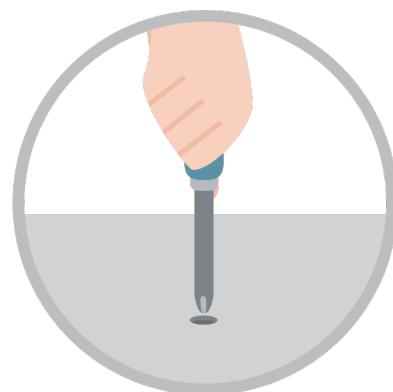

After two weeks, check and tighten any loose hardware and repeat again every six months thereafter.

IT IS THE USER'S RESPONSIBILITY TO MAINTAIN THE FURNITURE. THE HARDWARE MAY LOOSEN OVER TIME AND MAY CAUSE THE FURNITURE TO BE WOBBLY AND UNABLE TO SUPPORT ITS INTENDED WEIGHT CAPACITY. THIS MAY LEAD TO COLLAPSE AND MAY CAUSE SERIOUS INJURY.

DAY BED

CM1739 



• Please keep instructions for future reference.
• Check the quantity and irregularity of parts and hardware before you start.

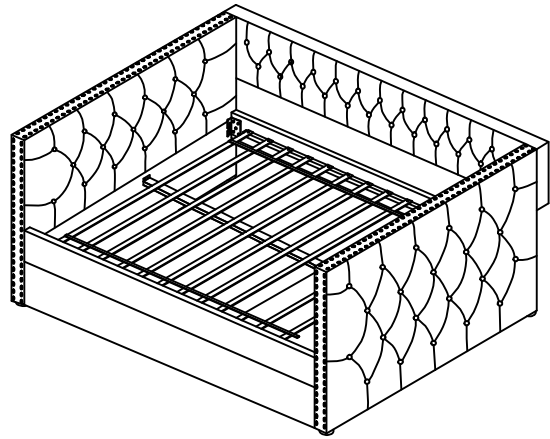

PARTS

#1 2pcs

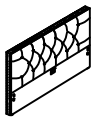

Arm(L&R)

#2 1pc

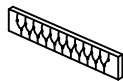

Top Back Panel

#3 2pcs



Top Side Rails

#4 1pc



Bottom Front Panel

#5 1pc



Bottom Back Panel

#6 2pcs

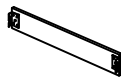

Bottom Side Panels

#7 1Set

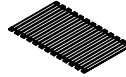

Top Slat (13pcs)

#8 1Set

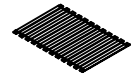

Bottom Slat (12pcs)

#9 1pc



Top Center Support Rail

#10 1pc



Bottom Center Support Rail

#11 4pcs



Plastic feet

HARDWARE

#A 8pcs

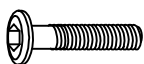

Bolt Ø5/16" x 1-1/2"

#B 4pcs

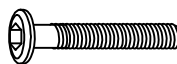

Bolt Ø5/16" x 2-1/2"

#C 8pcs

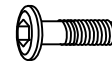

Bolt Ø5/16" x 3/4"

HARDWARE

#D 20pcs



Spring Washer Ø5/16"

#E 16pcs



Flat Washer Ø5/16"x19mm

#F 4pcs

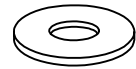

Flat Washer Ø5/16"x22mm

#G 75pcs

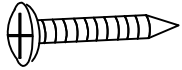

Screw #8 x 32mm

#H 4pcs

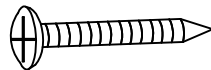

Screw #8 x 50mm



#I 1pc

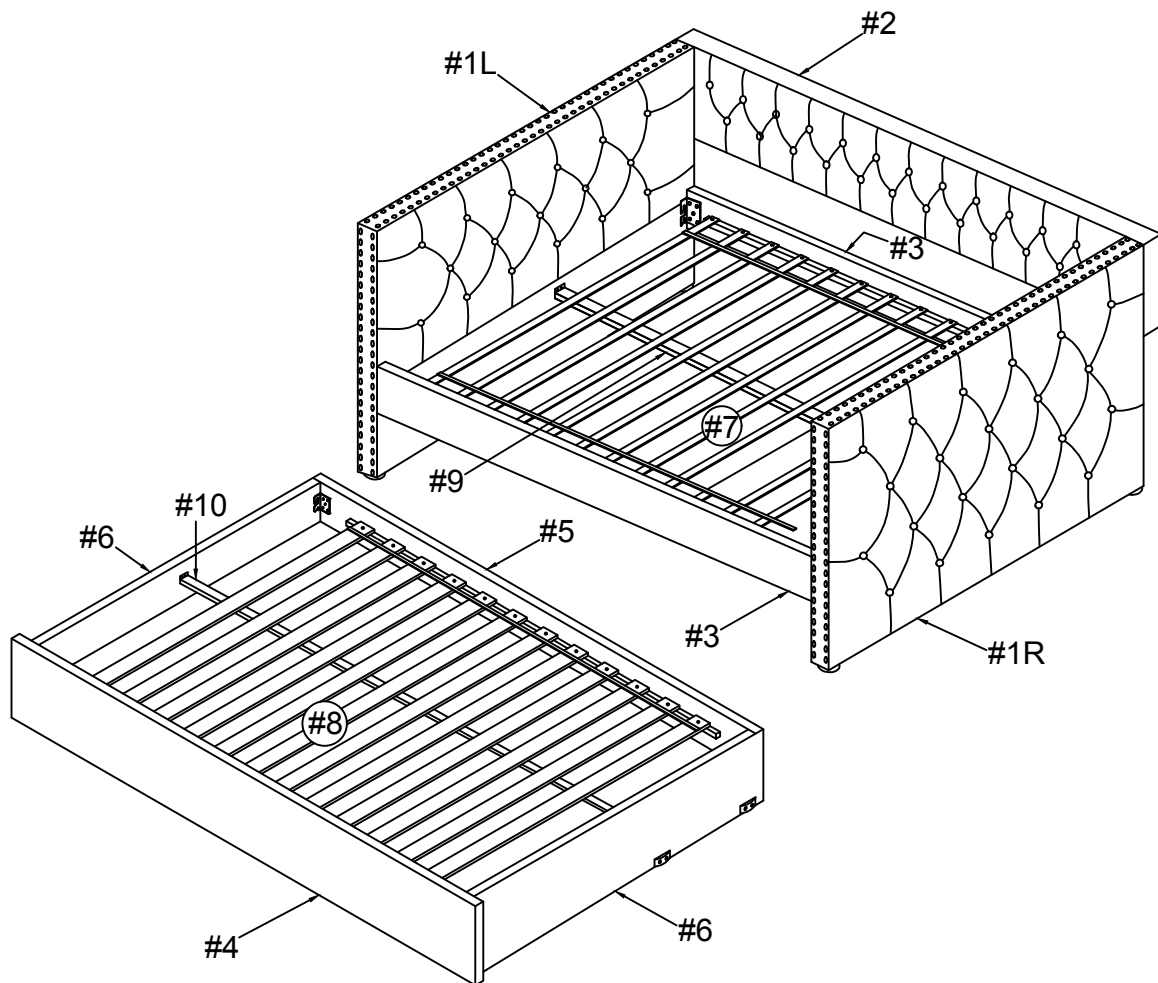

Allen Key 5mm

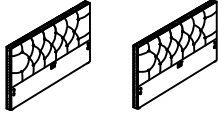
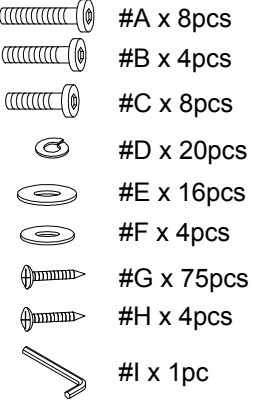
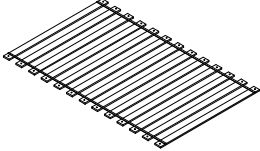
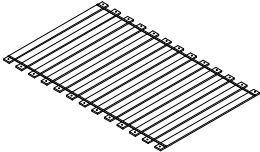
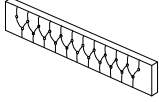
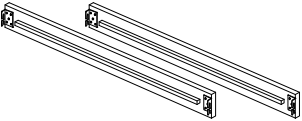
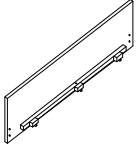
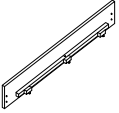
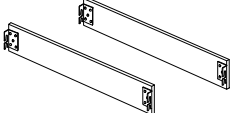
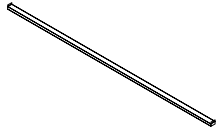
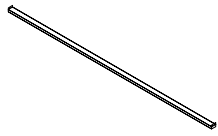

CM1739 (VN) is packed in 2 cases

Carton	Disignation	Part	Hardware
CM1739 (VN) -1	Arm (L&R)	#1 	
	Slat Up	#7 	
	Slat Down	#8 	
CM1739 (VN) -2	Top Back Panel	#2 	
	Top Side Rail	#3 	
	Bottom Front Panel	#4 	
	Bottom Back Panel	#5 	
	Bottom Side	#6 	
	Top center wood supportor (long)	#9 	
	Top center wood supportor (short)	#10 	
	Plastic feet	#11 	

ASSEMBLY INSTRUCTIONS

1

- Part #1 x1pc
- Part #11 x2pcs
- Hardware #H x2pcs

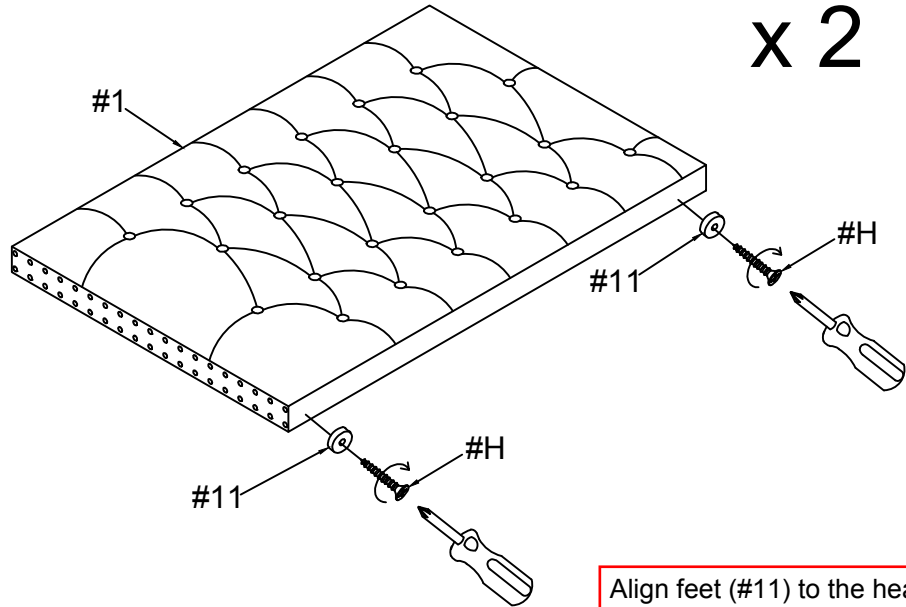

Align feet (#11) to the headboard (#1), then secure by using screws (#H).

2

- Part #3 x2pcs
- Hardware #A x8pcs
- Hardware #D x8pcs
- Hardware #E x8pcs

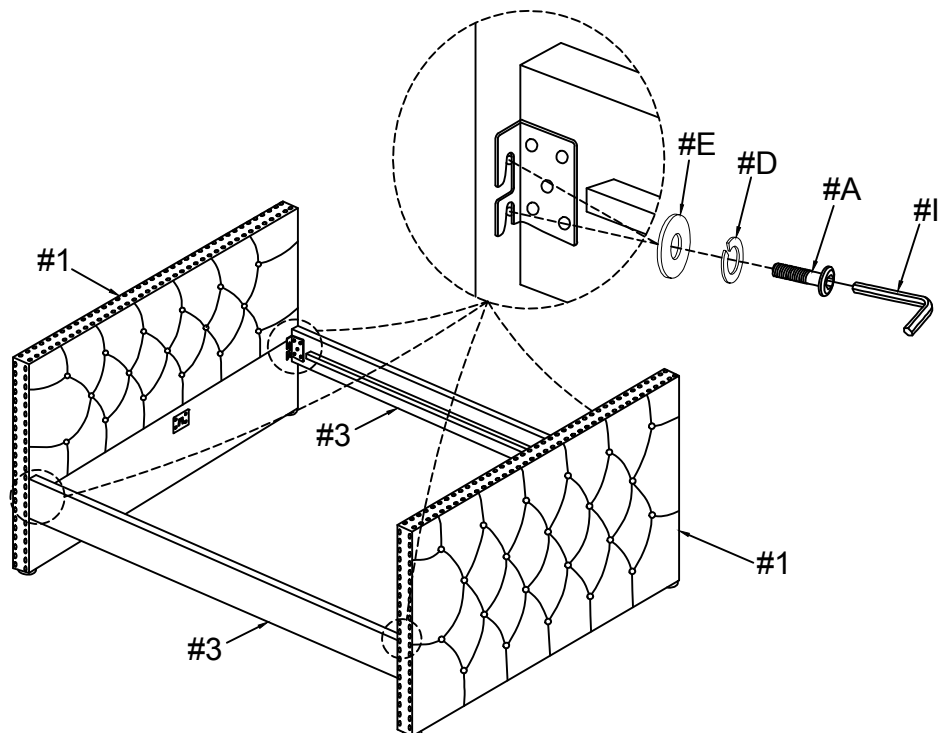

Align side rails (#3) to the headboards (#1), then secure by using bolts (#A) with washers (#D,E).

ASSEMBLY INSTRUCTIONS

3

Part #9 x1pc

Align and attach the center support rail (#9) to the headboard (#1).

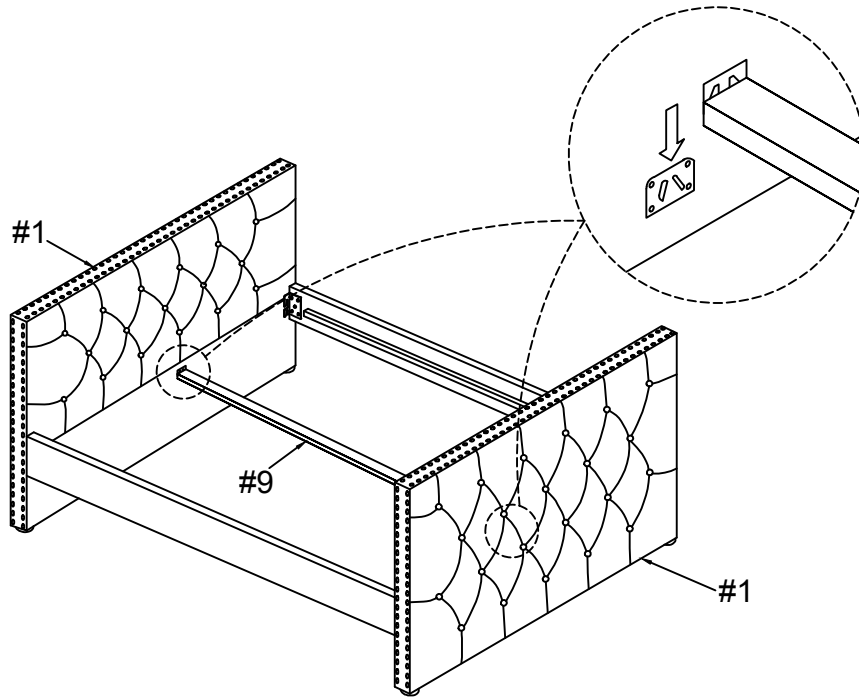

4

Part #2 x1pc

Hardware #B x4pcs

Hardware #D x4pcs

Hardware #F x4pcs

Align back panel (#2) to the headboards (#1), then secure by using bolts (#B) with washers (#D,F).

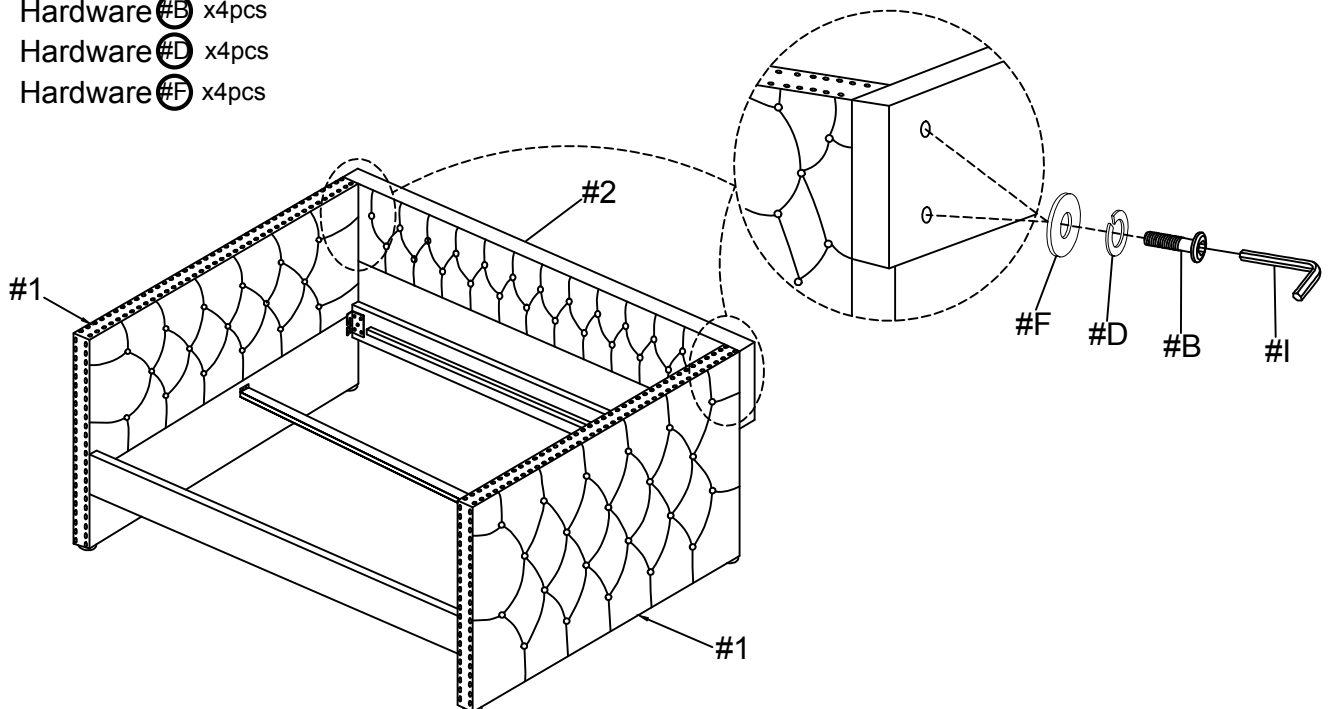

ASSEMBLY INSTRUCTIONS

Align slats (#7) to the rails, then secure by using screws (#G).

5

Part #7 x1set
Hardware #G x39pcs

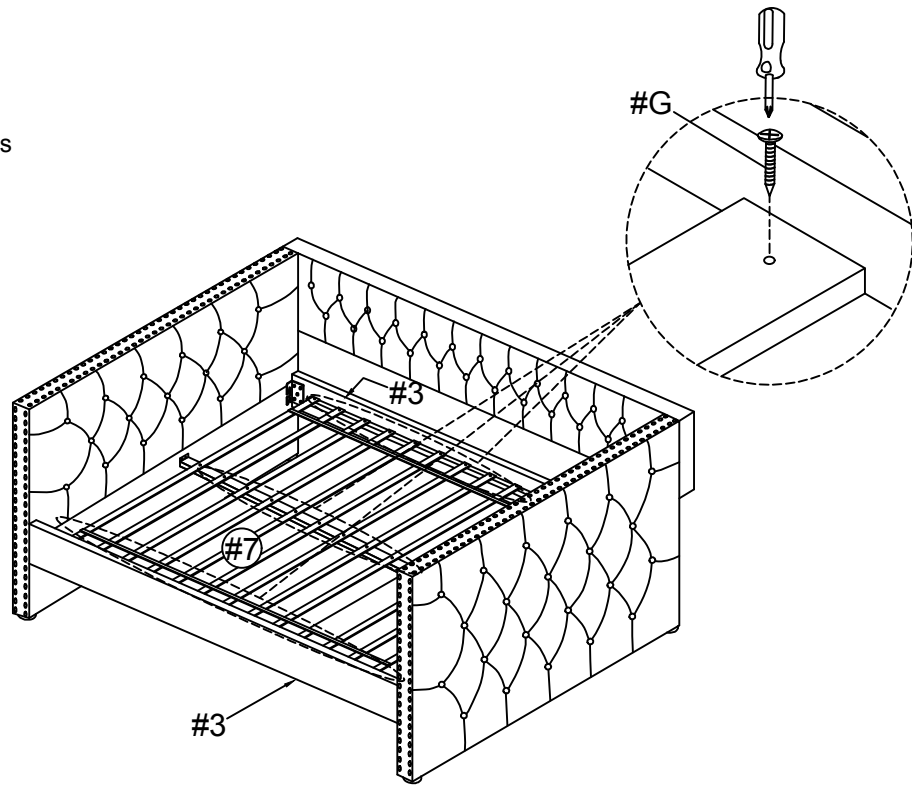

6

Part #4 x1pc
Part #5 x1pc
Part #6 x2pcs
Hardware #C x8pcs
Hardware #D x8pcs
Hardware #E x8pcs

Align front and back trundle panels (#4,5) to the trundle side panels (#6), then secure by using bolts (#C) with washers (#D,E).

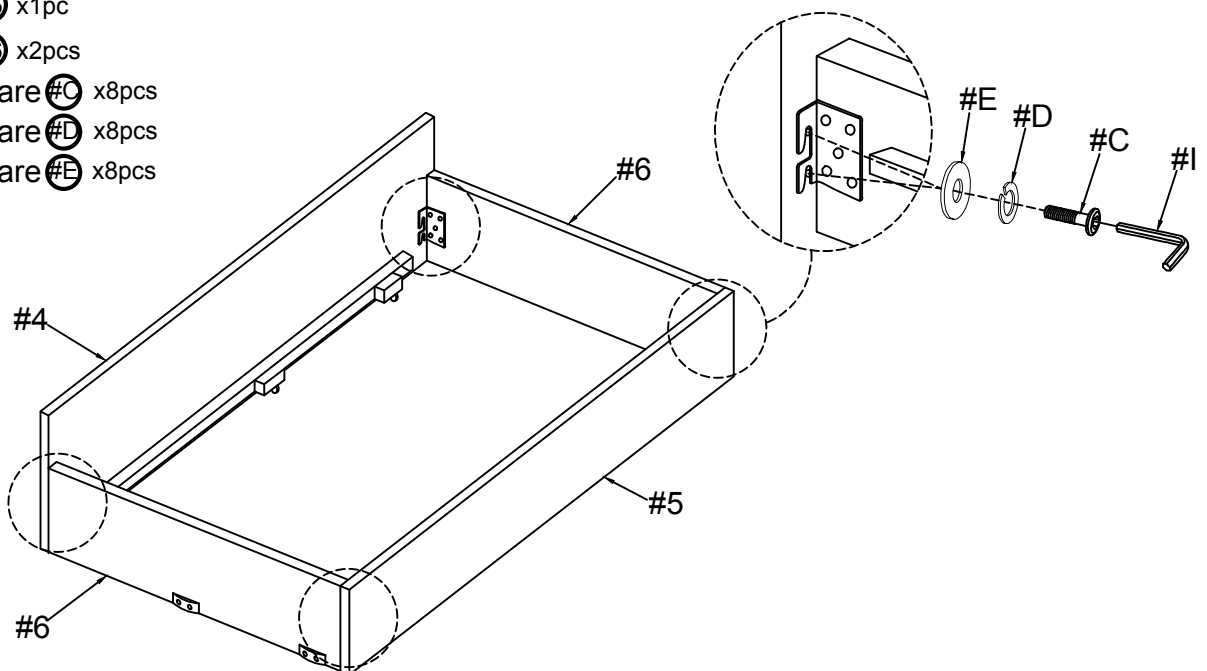

ASSEMBLY INSTRUCTIONS

7

Part #10 x1pc

Align and attach the trundle center support rail (#10) to the side rails (#6).

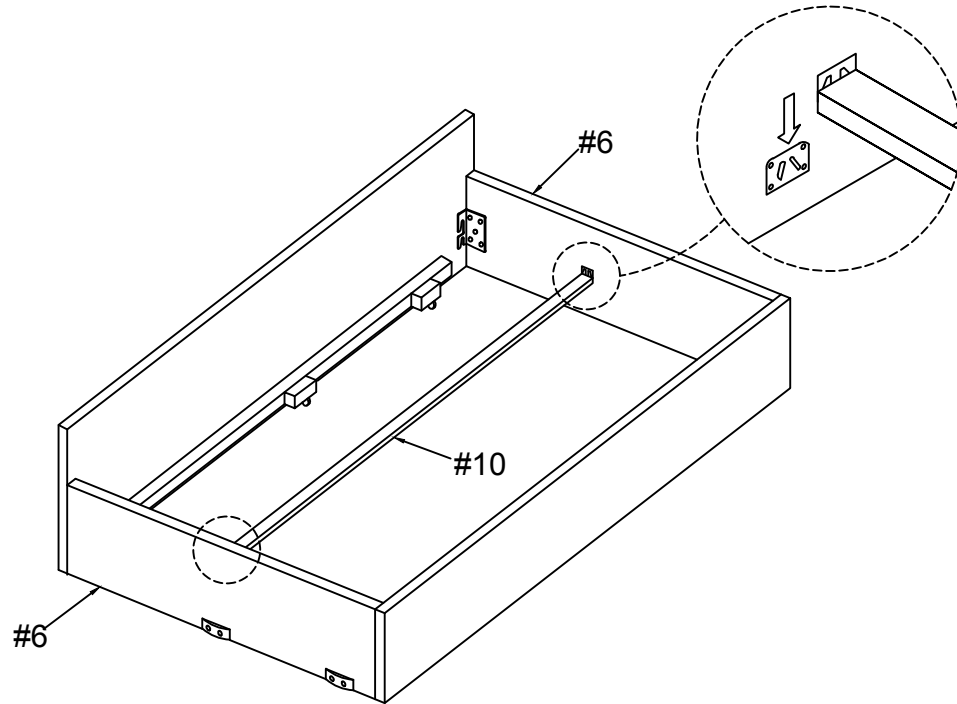

8

Part #8 x1set
Hardware #C x36pcs

Align slats (#8) to the front and back panels, then secure by using screws (#G).

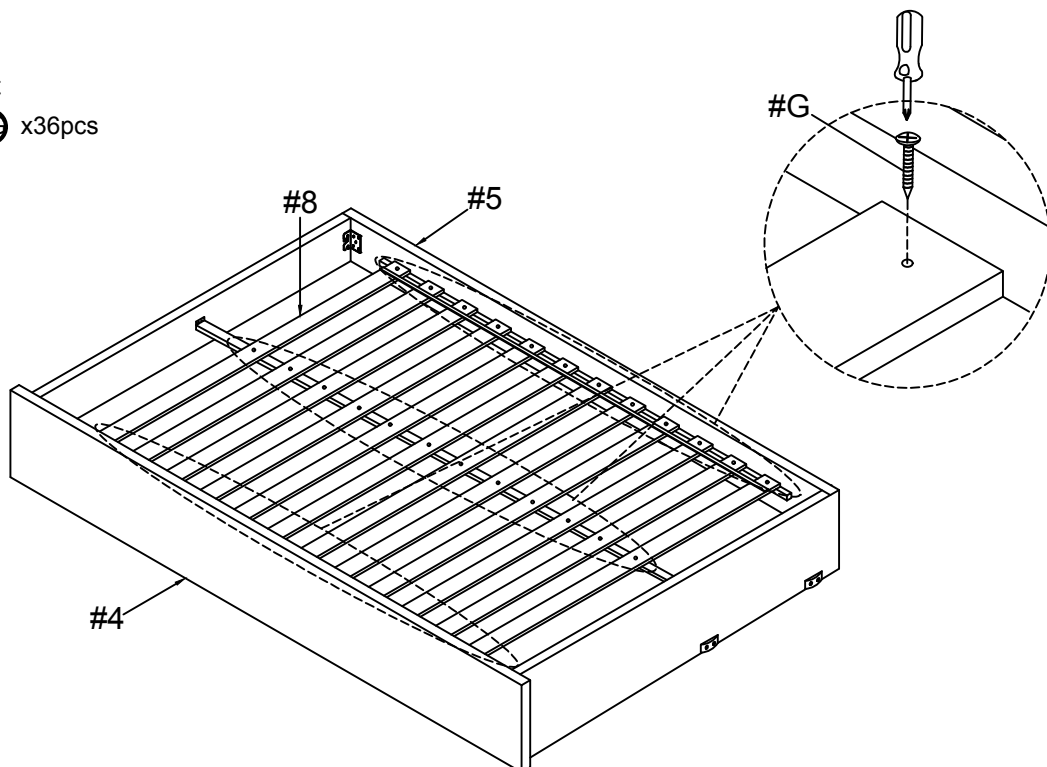

ASSEMBLY INSTRUCTIONS

9

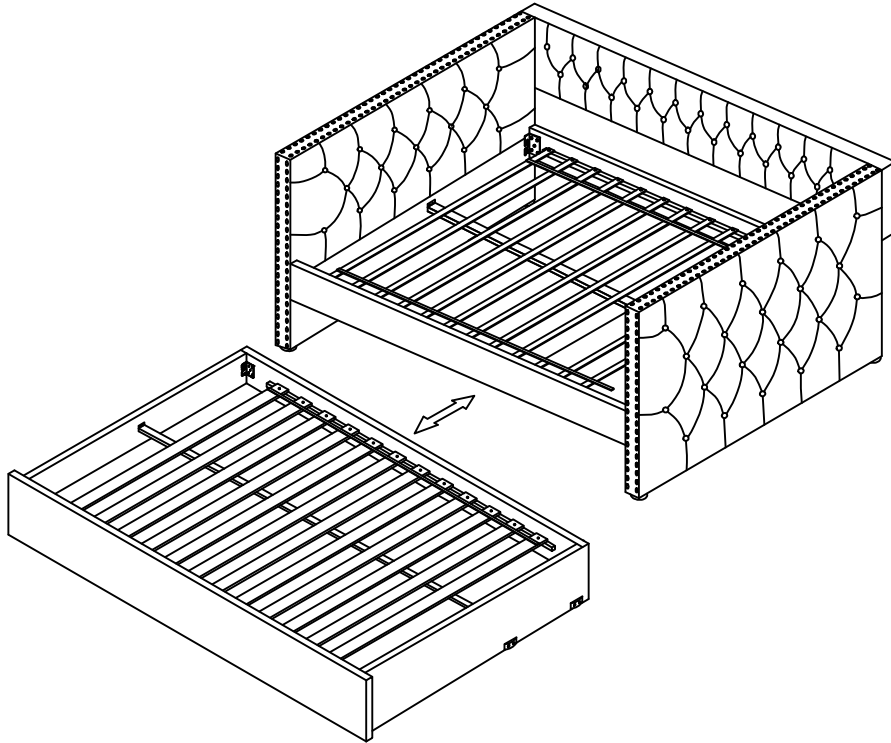

10

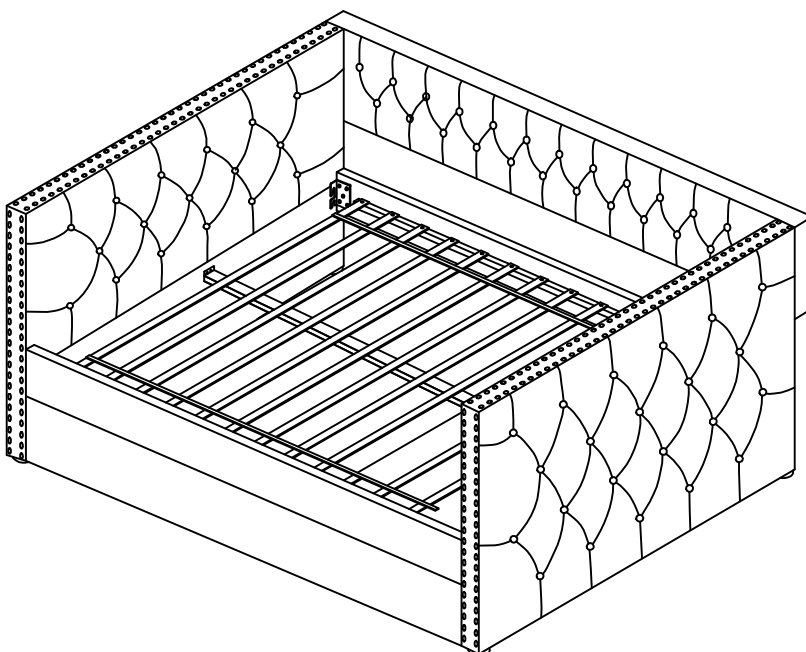

ASSEMBLY COMPLETED



Please ensure the furniture rests on an even and flat surface. If the product wobbles or feels loose, double-check all bolts and/or screws are properly tightened and secured.

✔ **Keep this handy!**

Please retain this instruction manual and any order-related information for future reference.

✔ **Lift, don't drag!**

To avoid damage to product please always LIFT the product when transporting or adjusting the placement.