

Furniture of America®

Assembly Instructions

CM7072Q

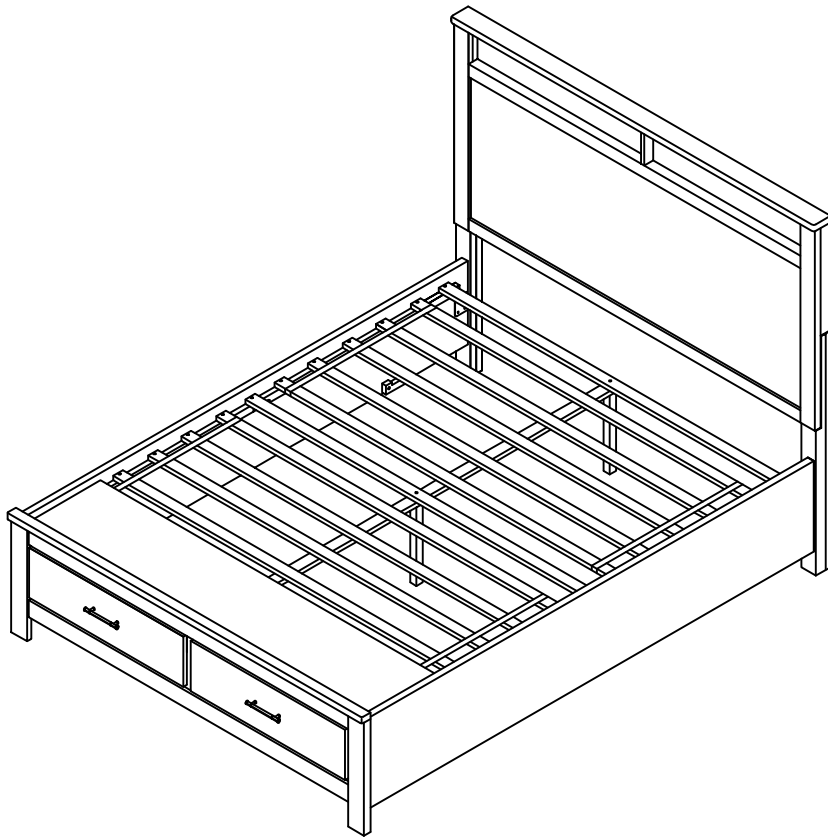

ASSEMBLY RATING

The Assembly Rating is a 5-point system that shows the degree of effort needed in assembling a specific product (with 1 being easy and 5 being difficult). For some products, two persons are recommended.

EASY



DIFFICULT

Tools Required For Assembly:

Allen Wrench

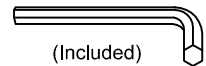

(Included)

Phillips Screwdriver



(Not Included)

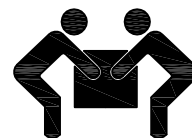

2 PERSONS RECOMMENDED

ASSEMBLY & CARE ADVICE

FOR YOUR FURNITURE TO LAST, CORRECT ASSEMBLY AND PROPER MAINTENANCE ARE NECESSARY. PLEASE FOLLOW THE INFORMATION PROVIDED BELOW TO FULLY ENJOY YOUR FURNITURE.

BASIC ASSEMBLY TECHNIQUES

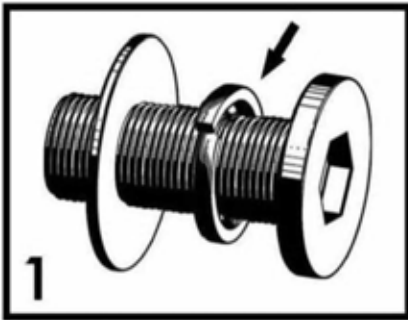

When lock or spring washer is used in an assembly, please make sure the lock or spring washer is placed between the larger flat washer and the head of the screw or bolt.



Position each part correctly and insert screws or bolts into their respective holes by hand tighten or using the proper hand tool. Only tighten when step is completed or when instructed to do so.

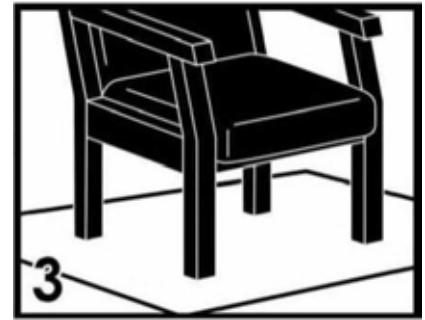

Use cardboard or carpet area when assembling furniture to prevent scratches. Make sure the furniture rests on a flat and level surface with each leg evenly touching the floor.

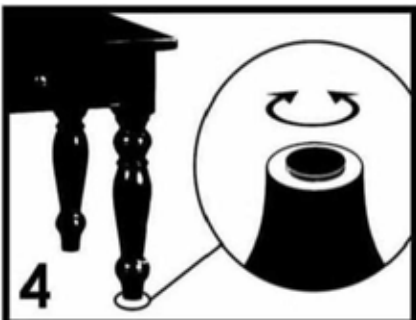

Some furniture comes with height adjustment knobs underneath each leg. To lower or to raise each leg, you need to turn clockwise or counterclockwise, respectively.

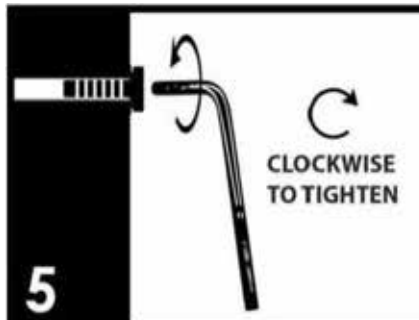

Make sure all parts are properly aligned, then use the appropriate hand tool to completely tighten the bolts or screws. Do not use power tools and do not overtighten.



Save the instructions and store the Allen wrench or any supplied tool for later maintenance. After two weeks, check and tighten any loose hardware and repeat again every six months thereafter.

IT IS THE USER'S RESPONSIBILITY TO MAINTAIN THE FURNITURE. THE HARDWARE MAY LOOSEN OVER TIME AND MAY CAUSE THE FURNITURE TO BE WOBBLY AND UNABLE TO SUPPORT ITS INTENDED WEIGHT CAPACITY. THIS MAY LEAD TO COLLAPSE AND MAY CAUSE SERIOUS INJURY.

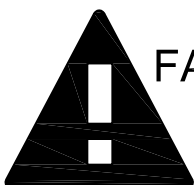

FAILURE TO FOLLOW THE GUIDELINES ABOVE MAY RESULT IN INJURY AND/OR PROPERTY DAMAGE.



Before you begin, please read Page 2 of "Assembly and Care Advice".

And remember, do not tighten until each step is completed or instructed.

Parts List

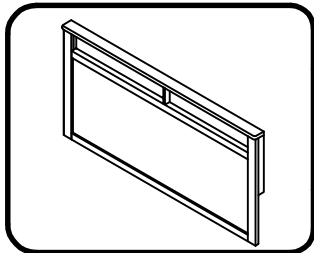

#1 x 1pc
Headboard Panel

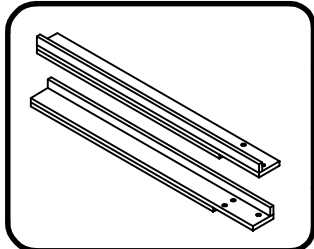

#2 x 2pcs
Headboard Legs L-R

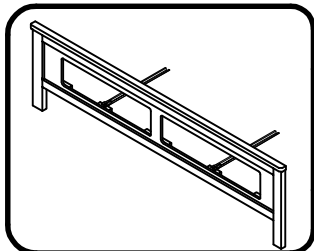

#3 x 1pc
Footboard Panel

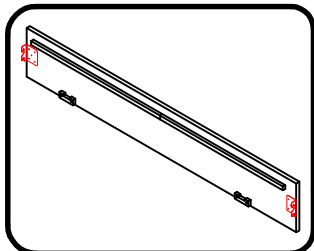

#4 x 2pcs
Side Rail

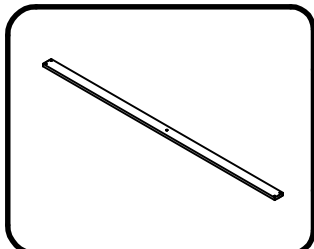

#5 x 1pc
Drawer Slat

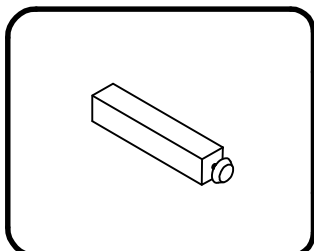

#6 x 1pc
Drawer Slat Support

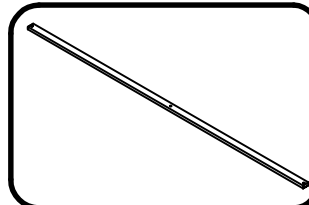

#7 x 3pcs
Bed Slat

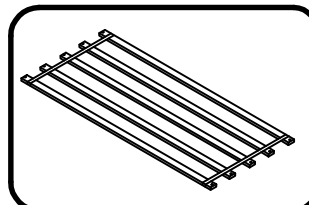

#8 x 2set
Bed Slat (5pcs X2)

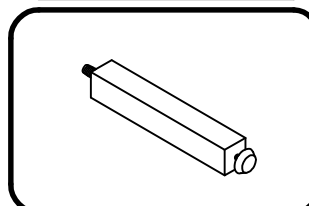

#9 x 3pcs
Slat Support Leg

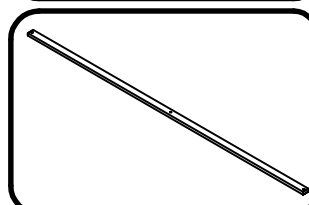

#10 x 1pc
Center Slat

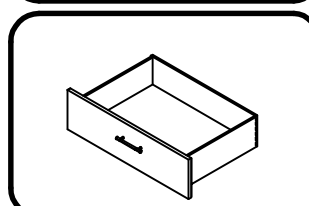

#11 x 2pcs
Drawer Box

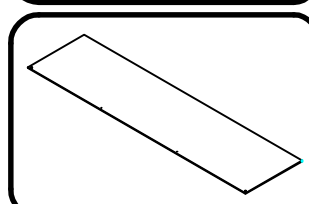

#12 x 1pc
Slat Cover

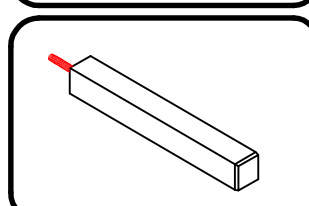

#13 x 1pc
Drawer Slat Support
Stopper



Before you begin, please read Page 2 of "Assembly and Care Advice".

And remember, do not tighten until each step is completed or instructed.

Hardware List

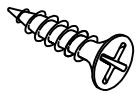

#A x 6pcs
Screw M4 x 5/8"



#E x 6pcs
Flat Washer $\text{\O} \frac{1}{4}$ "

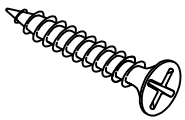

#B x 30pcs
Screw M4 x 1-1/4"



#F x 6pcs
Lock Washer $\text{\O} \frac{1}{4}$ "

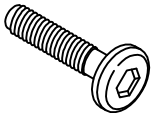

#C x 6pcs
Bolt M6 x 1-3/16"

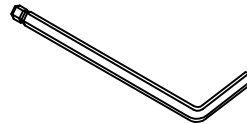

#G x 1pc
Allen Wrench M4

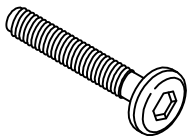

#D x 3pcs
Bolt M6 x 2"

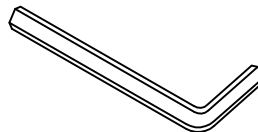

#H x 1pc
Allen Wrench M5



1. Prepare 6 bolt assemblies by first inserting a lock washer (#F) onto the bolt (#C) then a flat washer (#E) onto that same bolt (#C).

#C x 6pcs
#E x 6pcs
#F x 6pcs

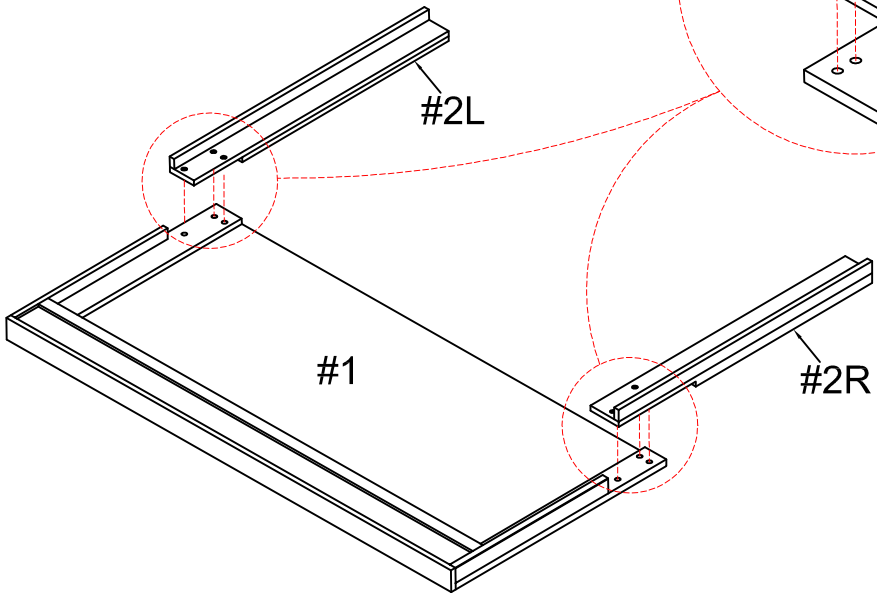
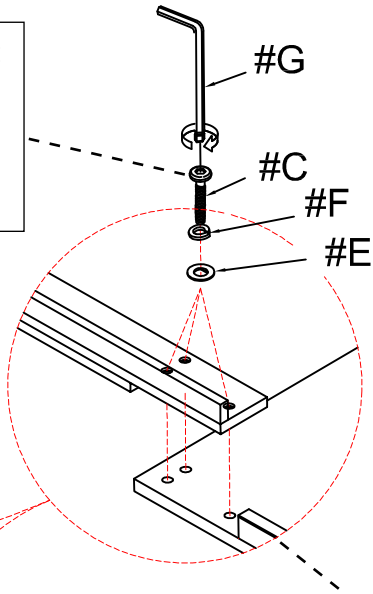

2. Align the legs (#2) to the holes along the back of the headboard (#1), then insert 3 bolt assemblies into each leg and secure.



Hook each end of the side rails (#4) onto the bolts along the headboard (#1) and footboard (#3), then tighten the bolts using the Allen wrench (#H).

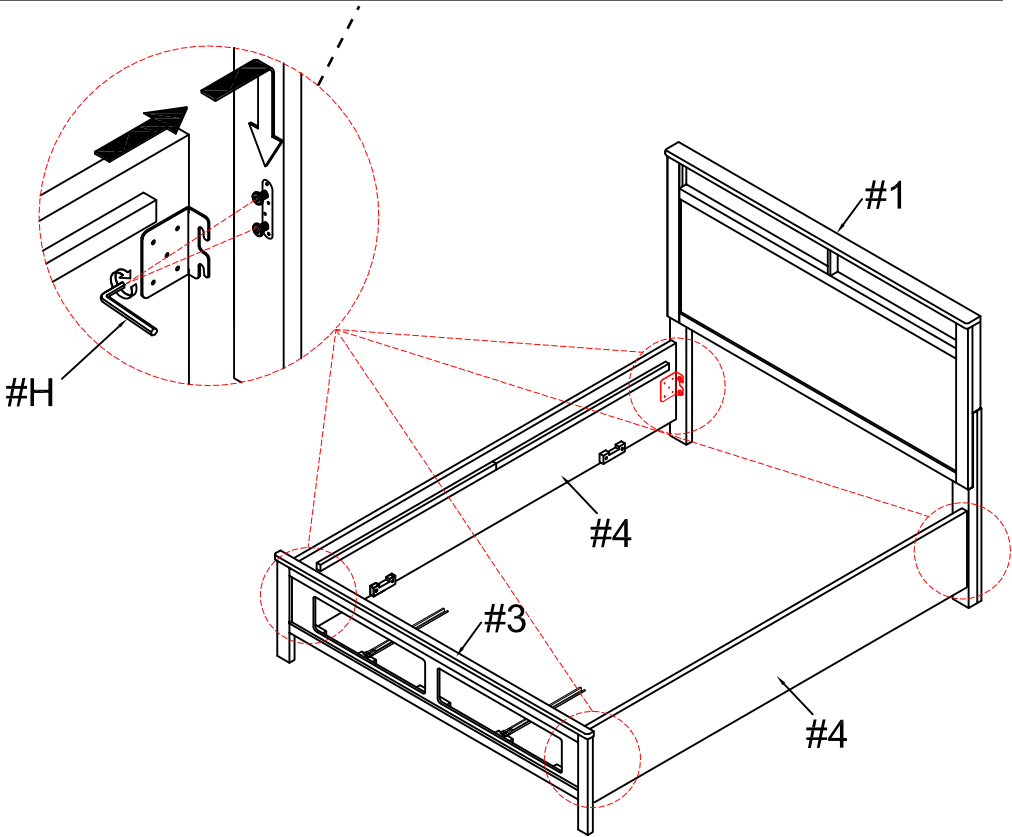



#3

#D x 1pc

Align the drawer slat support (#6) to the hole along the bottom of the drawer slat (#5), then insert the threaded end of the support stopper (#13) into that same hole from above. Turn right to tighten and make sure both supports are firmly secured.

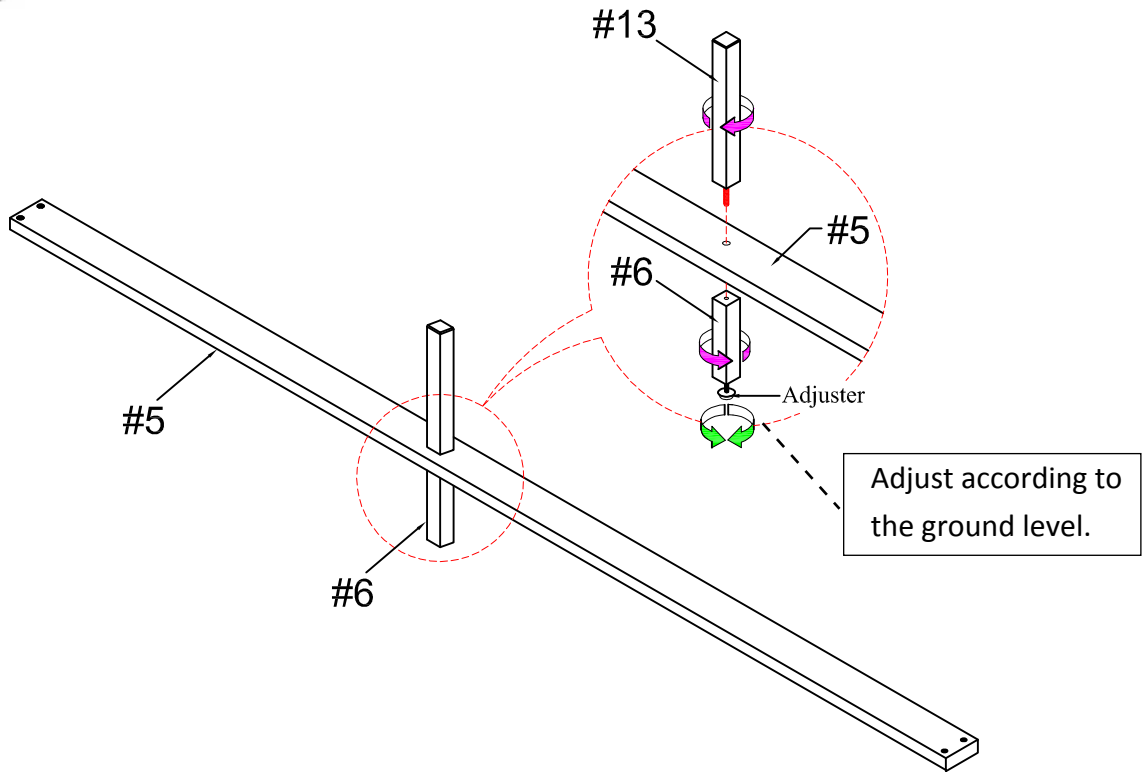

#4

#B x 4pcs

Place the ends of the drawer slat (#5) onto the slots along the rails, then insert 2 screws (#B) into each end. Secure using a screwdriver.

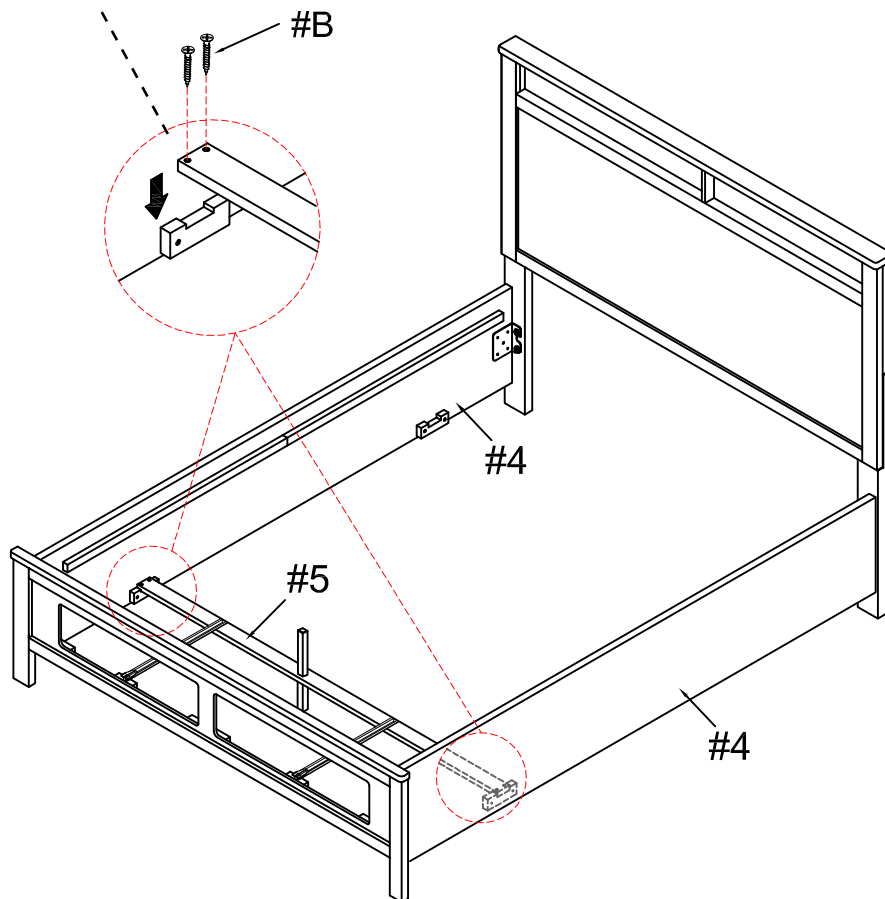



#5

Align the end of the runners to the slat (#5), then insert a screw (#A) into each end. Secure using a screwdriver.

#A x 2pcs

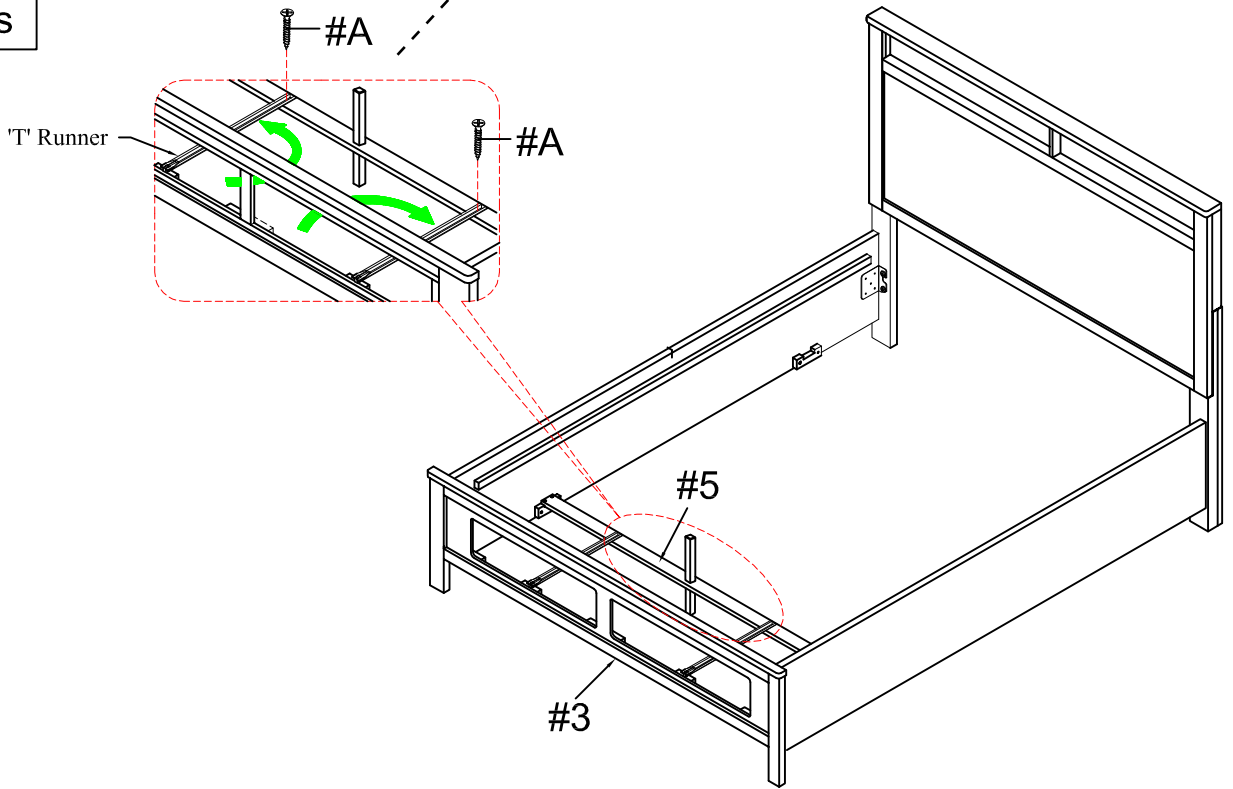

#6

Place the slats (#7) onto the rails, then align the center slat (#10) to the holes along the bottom of those slats (#7) and the slat supports (#9). Insert a bolt (#D) from above and secure.

#D x 3pcs

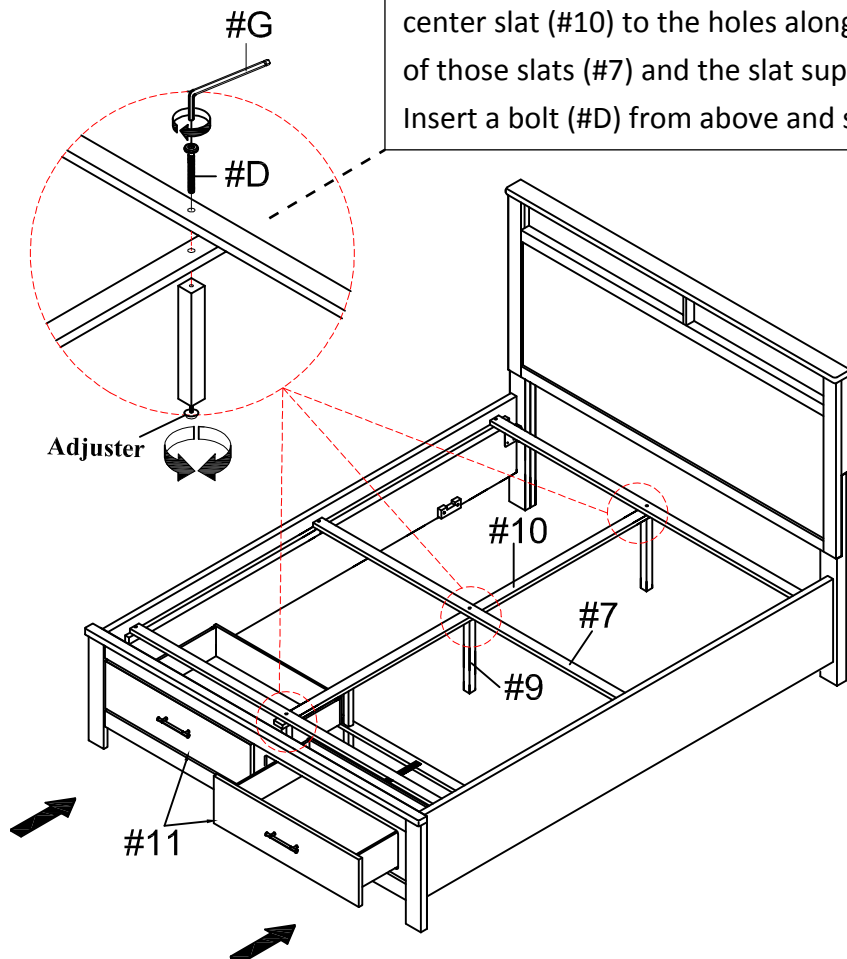



#7

#B x 26pcs

Place the bed slats (#8) onto the rails, then insert a screw (#B) into each end. Secure using a screwdriver.

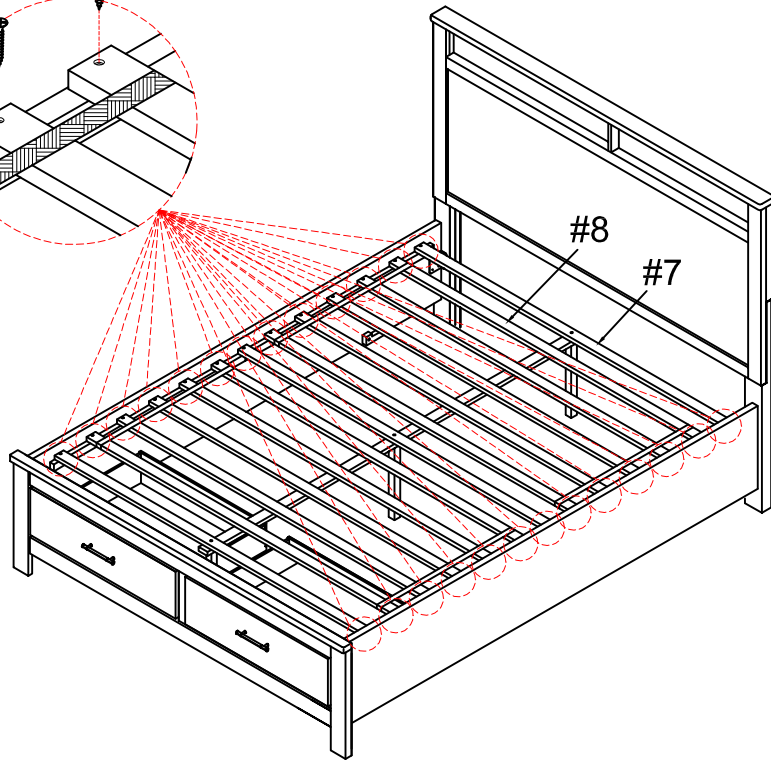
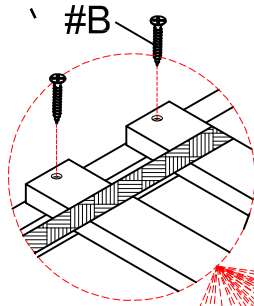

#8

#A x 4pcs

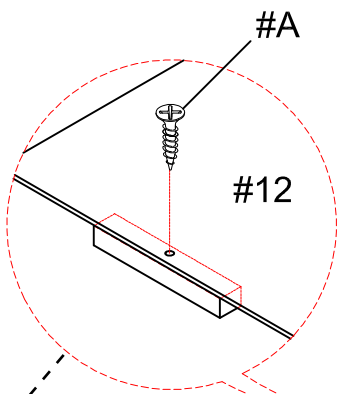

Place the slat cover (#12), then insert the screws (#A) and secure using a screwdriver.

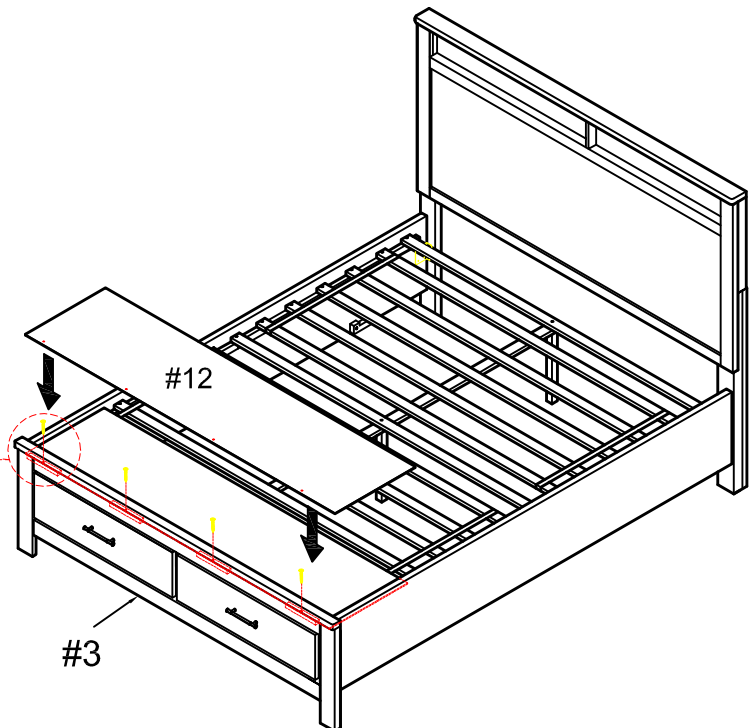

ASSEMBLY IS COMPLETED

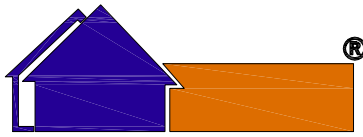

Furniture of America[®]

Assembly Instructions

CM7072CK

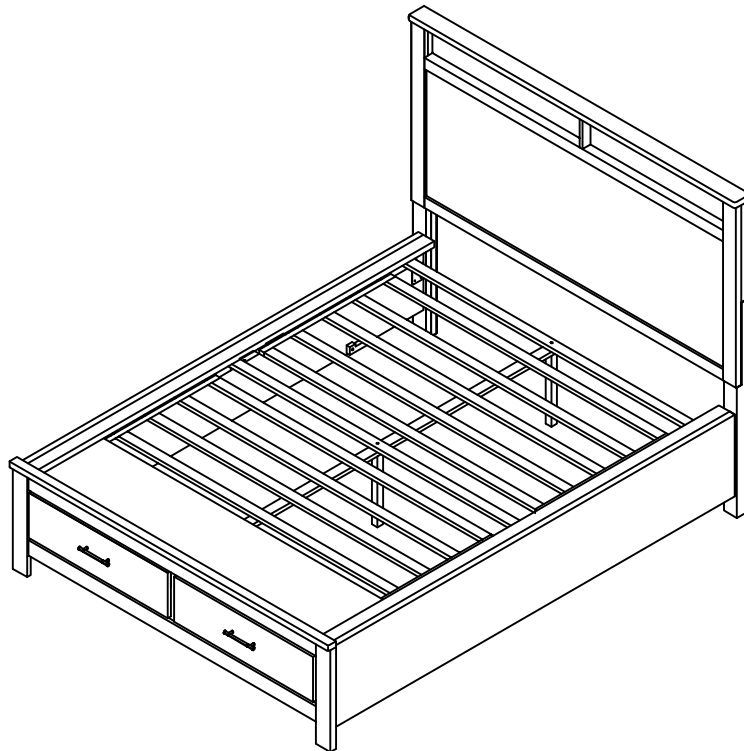

ASSEMBLY RATING

The Assembly Rating is a 5-point system that shows the degree of effort needed in assembling a specific product (with 1 being easy and 5 being difficult). For some products, two persons are recommended.

EASY



DIFFICULT

Tools Required For Assembly:

Allen Wrench

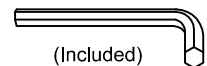

(Included)

Phillips Screwdriver

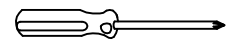

(Not Included)

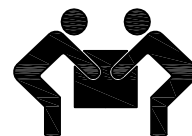

2 PERSONS RECOMMENDED

ASSEMBLY & CARE ADVICE

FOR YOUR FURNITURE TO LAST, CORRECT ASSEMBLY AND PROPER MAINTENANCE ARE NECESSARY. PLEASE FOLLOW THE INFORMATION PROVIDED BELOW TO FULLY ENJOY YOUR FURNITURE.

BASIC ASSEMBLY TECHNIQUES

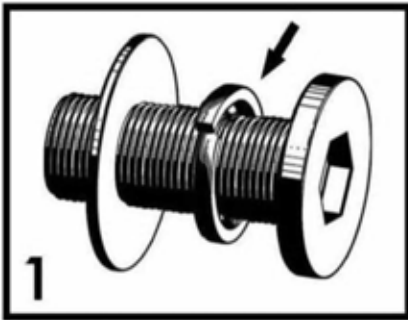

When lock or spring washer is used in an assembly, please make sure the lock or spring washer is placed between the larger flat washer and the head of the screw or bolt.



Position each part correctly and insert screws or bolts into their respective holes by hand tighten or using the proper hand tool. Only tighten when step is completed or when instructed to do so.

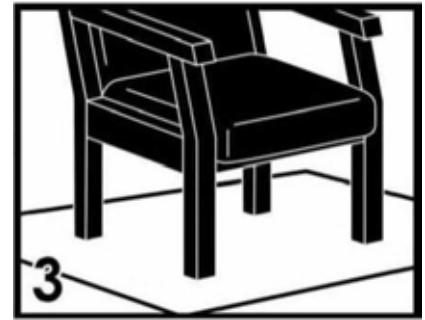

Use cardboard or carpet area when assembling furniture to prevent scratches. Make sure the furniture rests on a flat and level surface with each leg evenly touching the floor.

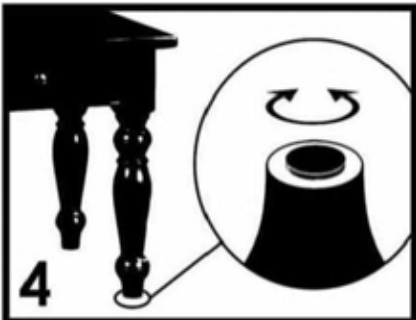

Some furniture comes with height adjustment knobs underneath each leg. To lower or to raise each leg, you need to turn clockwise or counterclockwise, respectively.

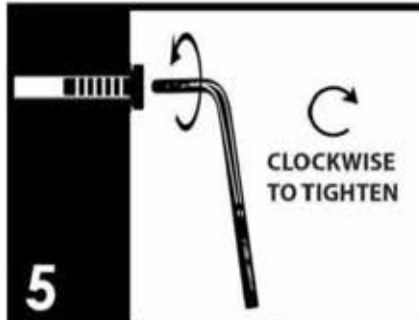

Make sure all parts are properly aligned, then use the appropriate hand tool to completely tighten the bolts or screws. Do not use power tools and do not overtighten.

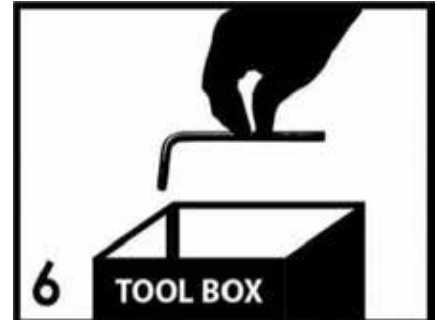

Save the instructions and store the Allen wrench or any supplied tool for later maintenance. After two weeks, check and tighten any loose hardware and repeat again every six months thereafter.

IT IS THE USER'S RESPONSIBILITY TO MAINTAIN THE FURNITURE. THE HARDWARE MAY LOOSEN OVER TIME AND MAY CAUSE THE FURNITURE TO BE WOBBLY AND UNABLE TO SUPPORT ITS INTENDED WEIGHT CAPACITY. THIS MAY LEAD TO COLLAPSE AND MAY CAUSE SERIOUS INJURY.

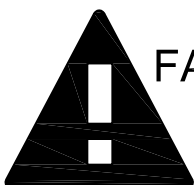

FAILURE TO FOLLOW THE GUIDELINES ABOVE MAY RESULT IN INJURY AND/OR PROPERTY DAMAGE.



Before you begin, please read Page 2 of "Assembly and Care Advice".

And remember, do not tighten until each step is completed or instructed.

Parts List

Hardware List

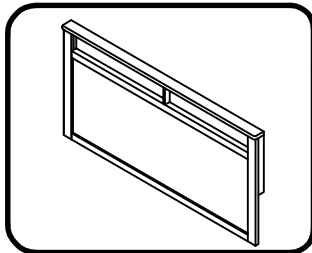

#1 x 1pc
Headboard Panel

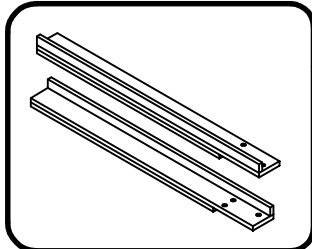

#2 x 2pcs
Headboard Legs L-R

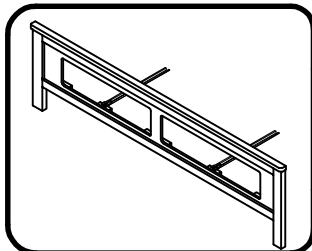

#3 x 1pc
Footboard Panel

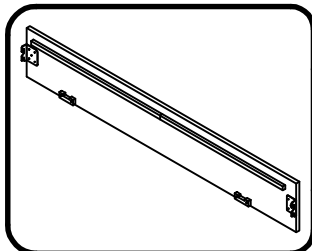

#4 x 2pcs
Side Rail

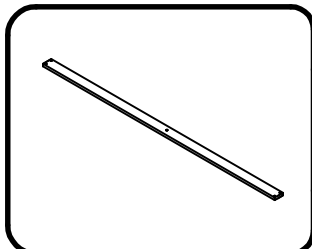

#5 x 1pc
Drawer Slat

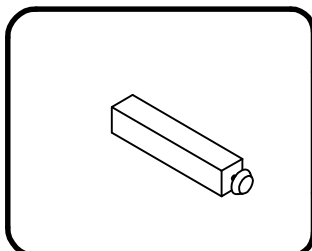

#6 x 1pc
Drawer Slat Support

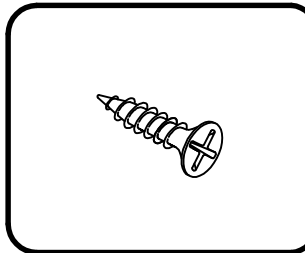

#A x 7pcs
Screw M4 x 5/8"

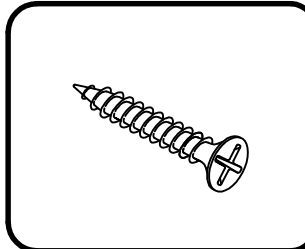

#B x 30pcs
Screw M4 x 1-1/4"

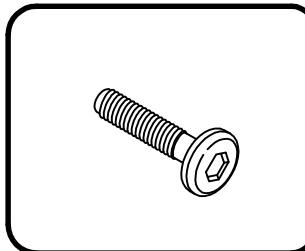

#C x 6pcs
Bolt M6 x 1-3/16"

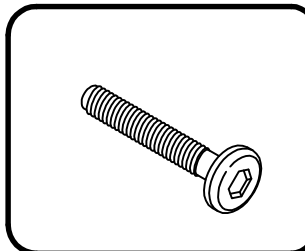

#D x 10pcs
Bolt M6 x 1-3/4"

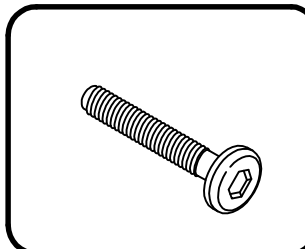

#E x 3pcs
Bolt M6 x 2"

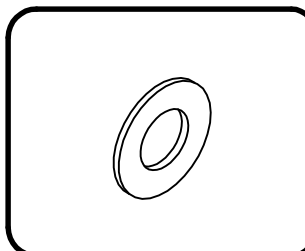

#F x 16pcs
Flat Washer $\text{Ø}\frac{1}{4}$ "



Before you begin, please read Page 2 of "Assembly and Care Advice".

And remember, do not tighten until each step is completed or instructed.

Parts List

Hardware List

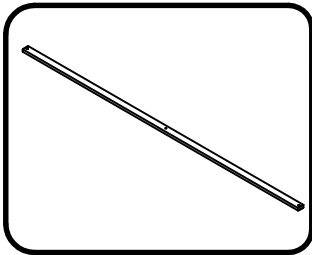

#7 x 3pcs
Bed Slat

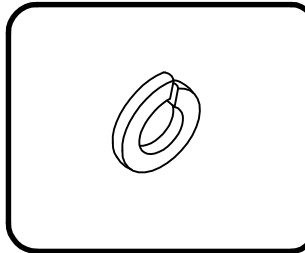

#G x 16pcs
Lock Washer $\text{\O} \frac{1}{4}$ "

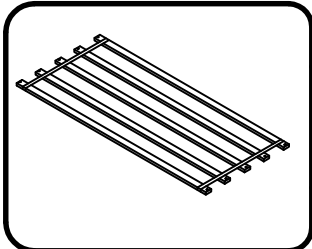

#8 x 2set
Bed Slat (5pcs X2)

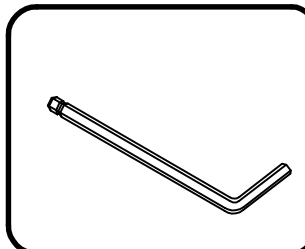

#H x 1pc
Allen Wrench M4

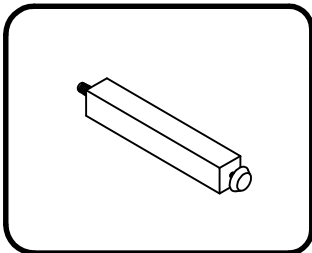

#9 x 3pcs
Slat Support Leg

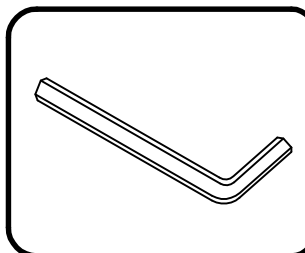

#I x 1pc
Allen Wrench M5

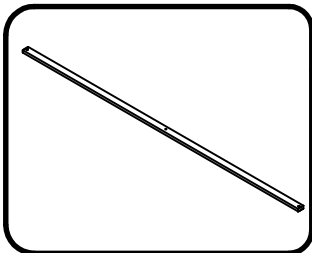

#10 x 1pc
Center Slat

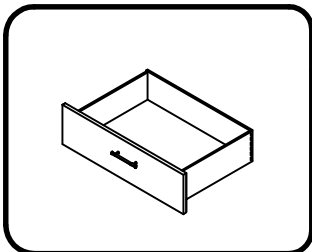

#11 x 2pcs
Drawer Box

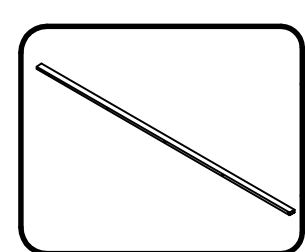

#13 x 2pcs
Siderail Cap

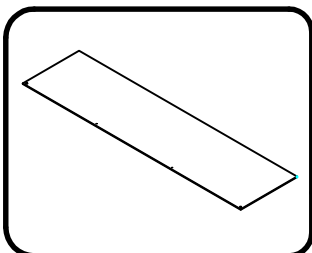

#12 x 1pc
Slat Cover

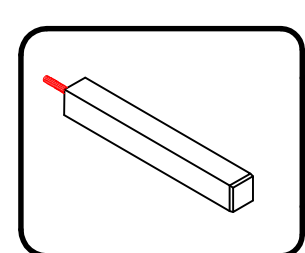

#14 x 1pc
Drawer Slat Support
Stopper



1. Prepare 6 bolt assemblies by first inserting a lock washer (#G) onto the bolt (#C) then a flat washer (#F) onto that same bolt (#C).

#C x 6pcs
#F x 6pcs
#G x 6pcs

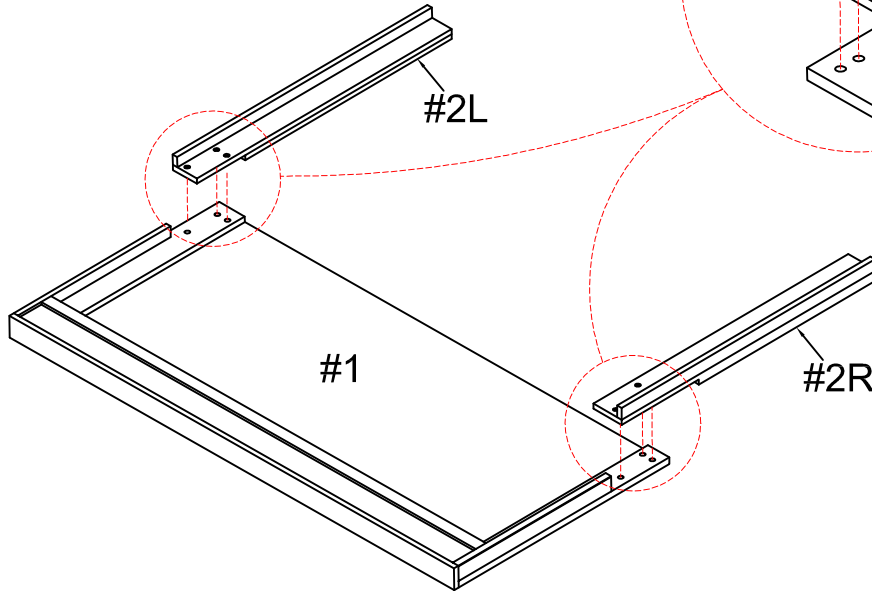
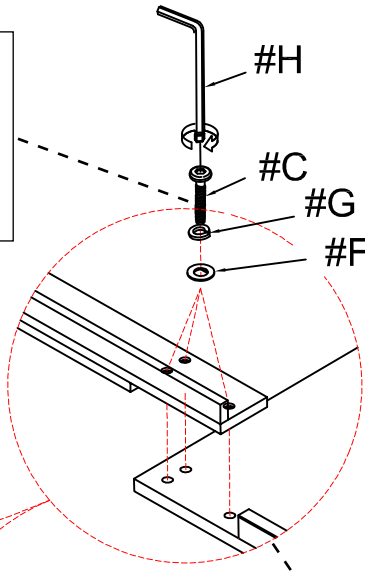

2. Align the legs (#2) to the holes along the back of the headboard (#1), then insert 3 bolt assemblies into each leg and secure.



Hook each end of the side rails (#4) onto the bolts along the headboard (#1) and footboard (#3), then tighten the bolts using the Allen wrench (#1).

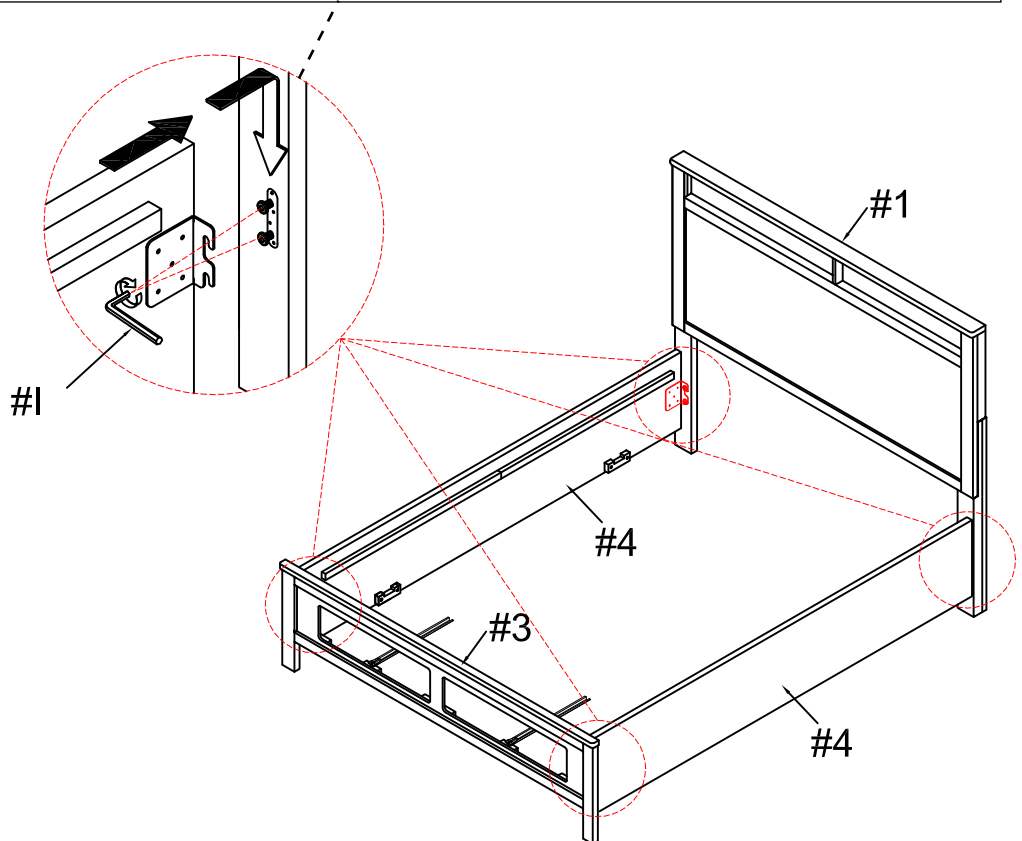



Align the drawer slat support (#6) to the hole along the bottom of the drawer slat (#5), then insert the threaded end of the support stopper (#14) into that same hole from above. Turn right to tighten and make sure both supports are firmly secured.

#E x 1pc

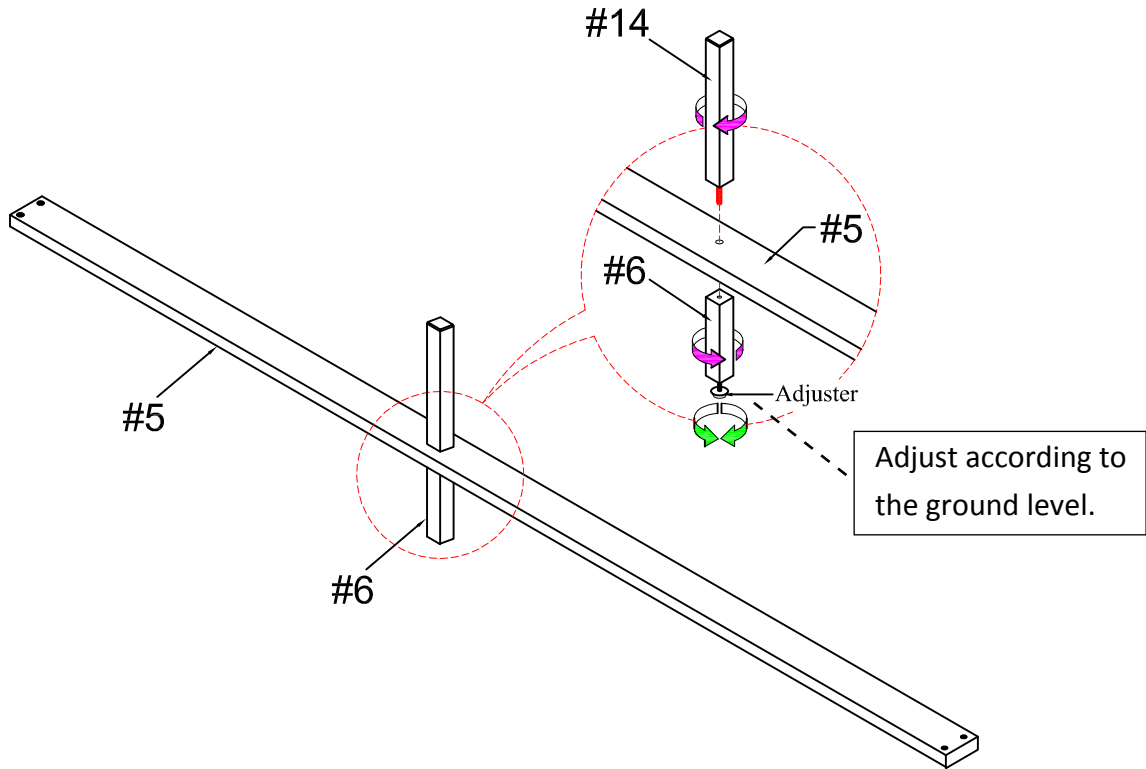

Place the ends of the drawer slat (#5) onto the slots along the rails, then insert 2 screws (#B) into each end. Secure using a screwdriver.

#B x 4pcs

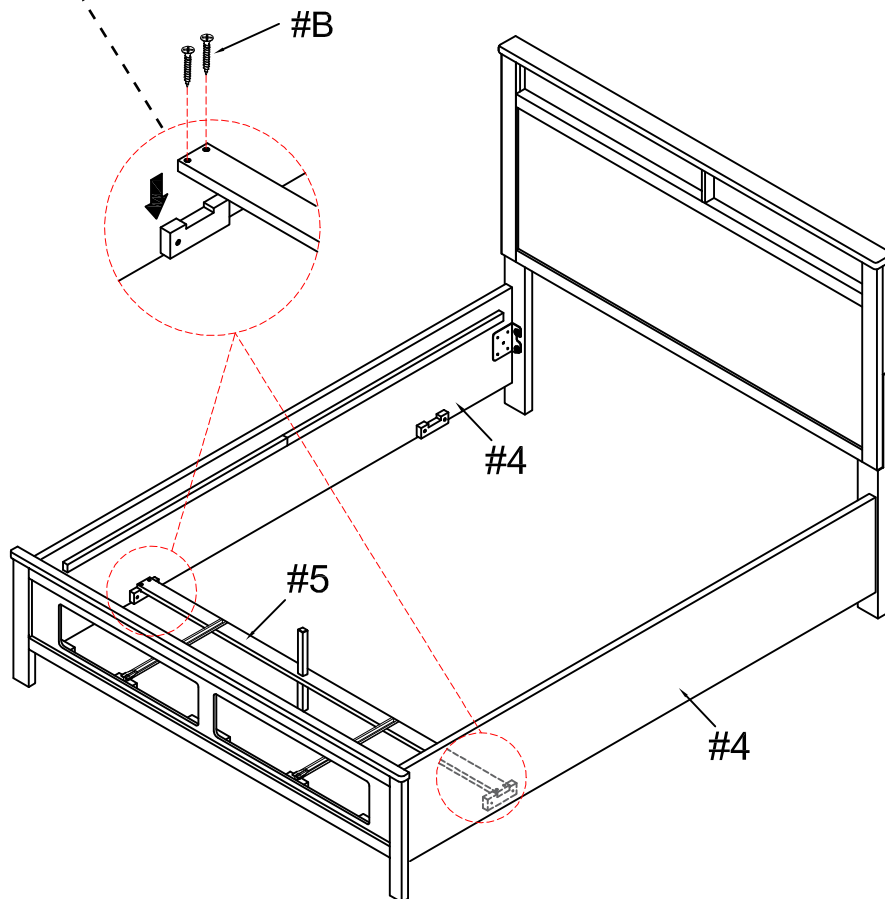



Align the end of the runners to the slat (#5), then insert a screw (#A) into each end. Secure using a screwdriver.

#A x 2pcs

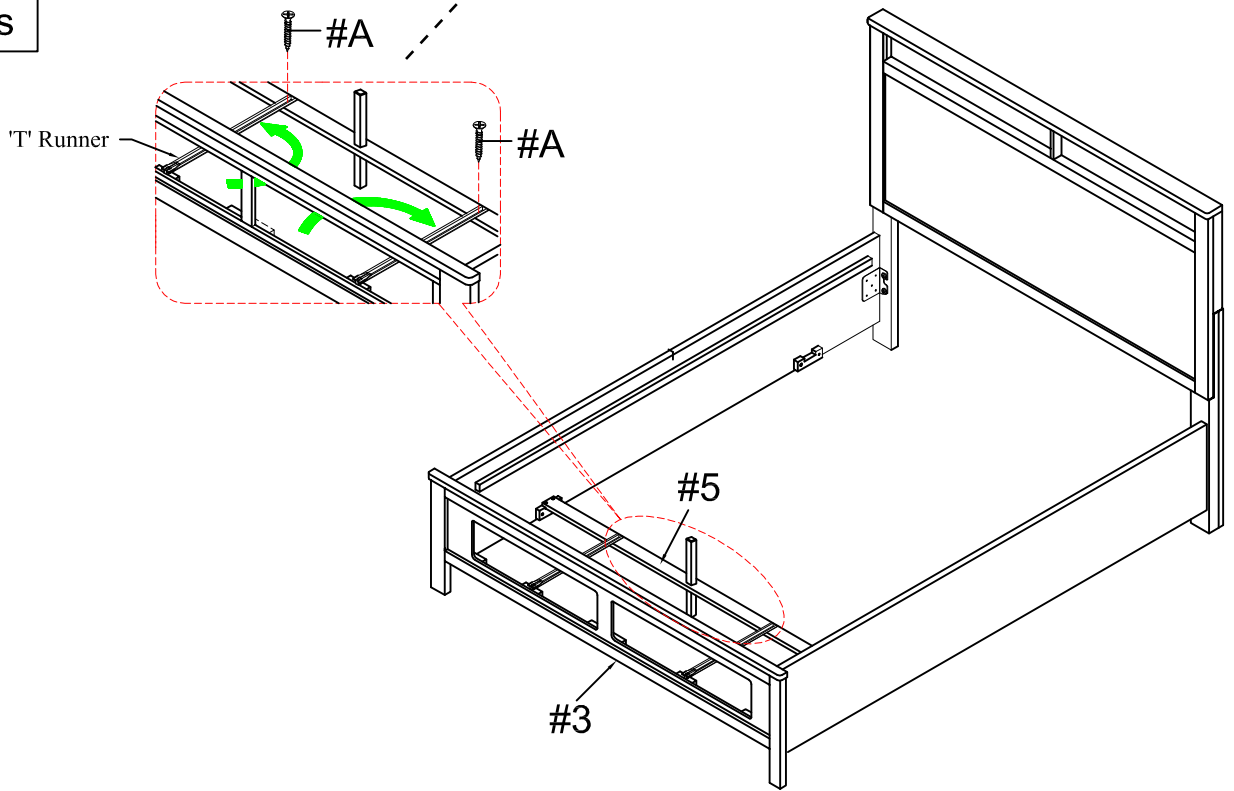

Place the slats (#7) onto the rails, then align the center slat (#10) to the holes along the bottom of those slats (#7) and the slat supports (#9). Insert a bolt (#E) from above and secure.

#E x 3pcs

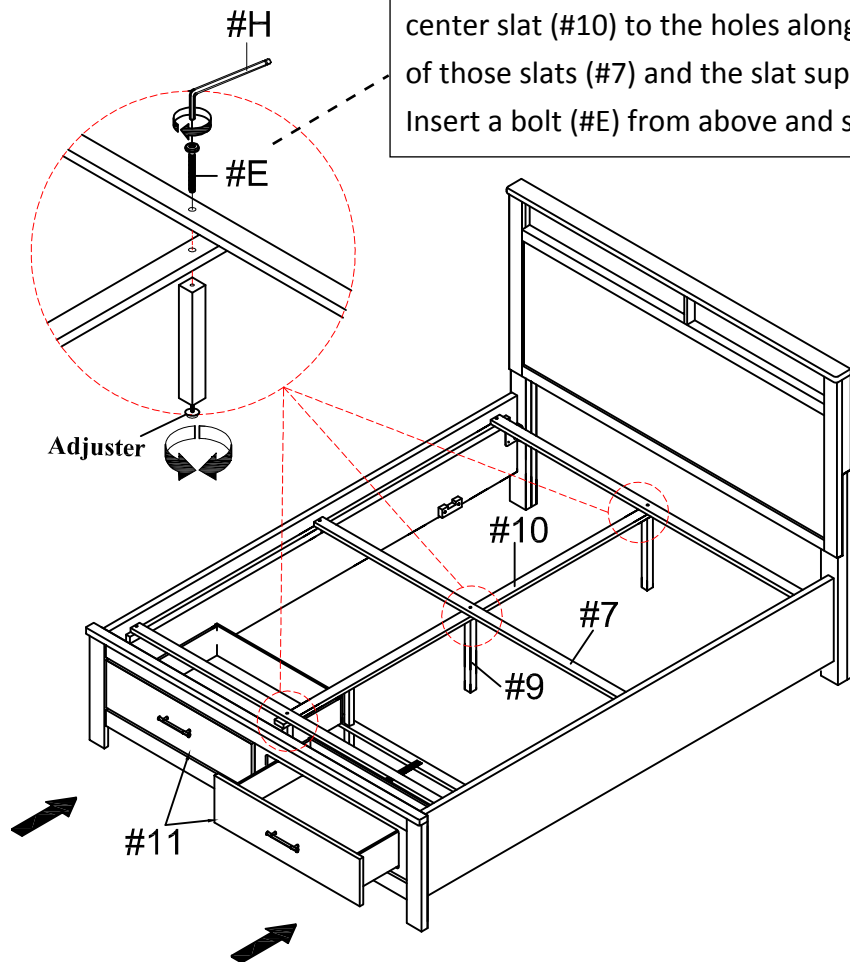

Insert the drawers.



#7

#B x 26pcs

Place the bed slats (#8) onto the rails, then insert a screw (#B) into each end. Secure using a screwdriver.

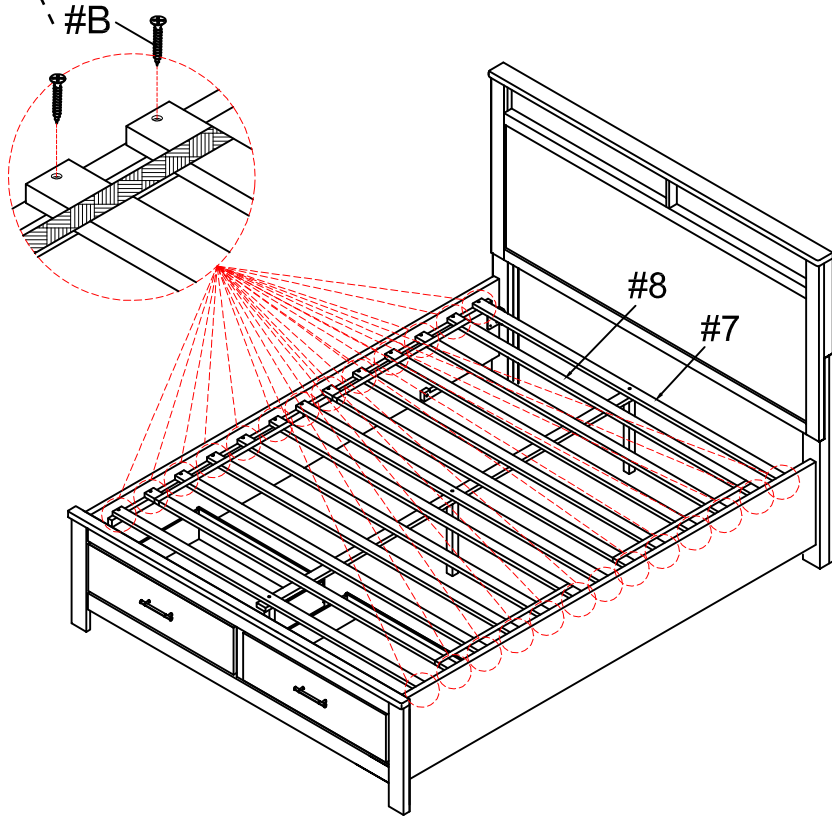

#8

#A x 5pcs

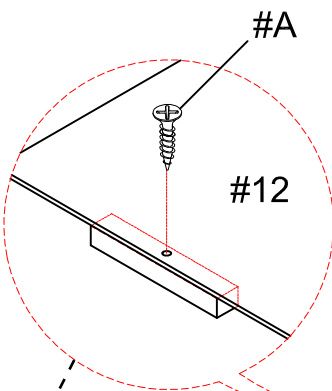

Place the slat cover (#12), then insert the screws (#A) and secure using a screwdriver.

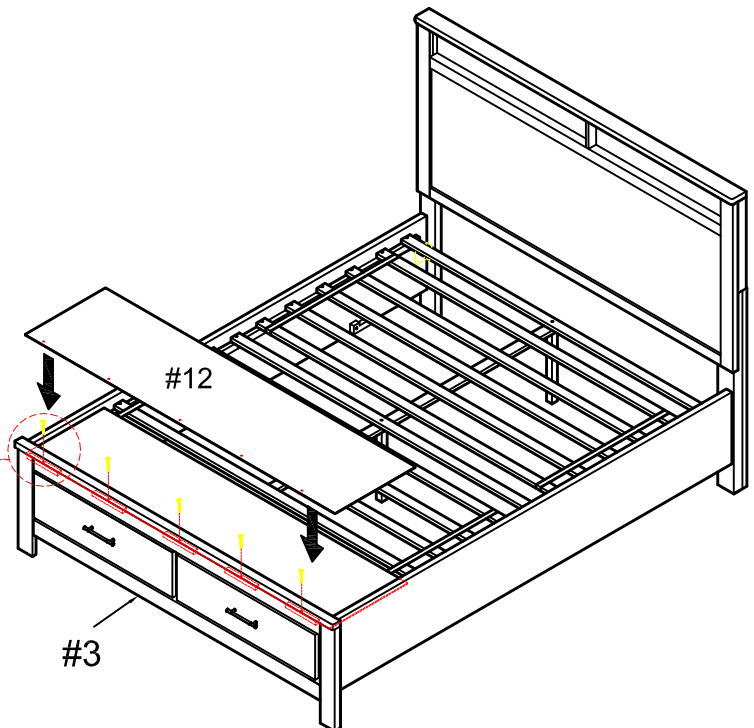



#D x 10pcs
 #G x 10pcs
 #F x 10pcs

2. Align the side rail caps (#13) to the holes, then insert a bolt assembly into each hole. Secure using the Allen wrench.

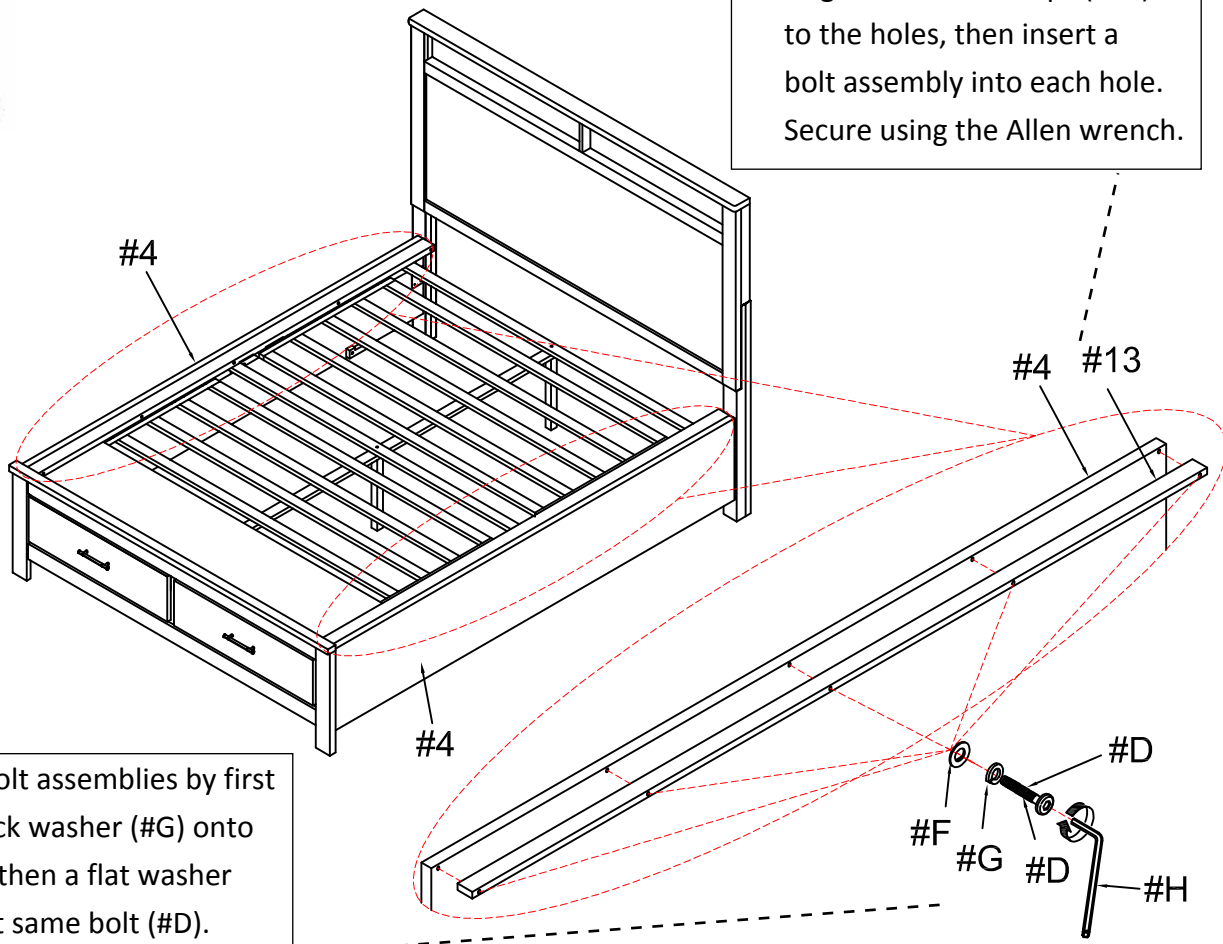

1. Prepare 10 bolt assemblies by first inserting a lock washer (#G) onto the bolt (#D) then a flat washer (#F) onto that same bolt (#D).

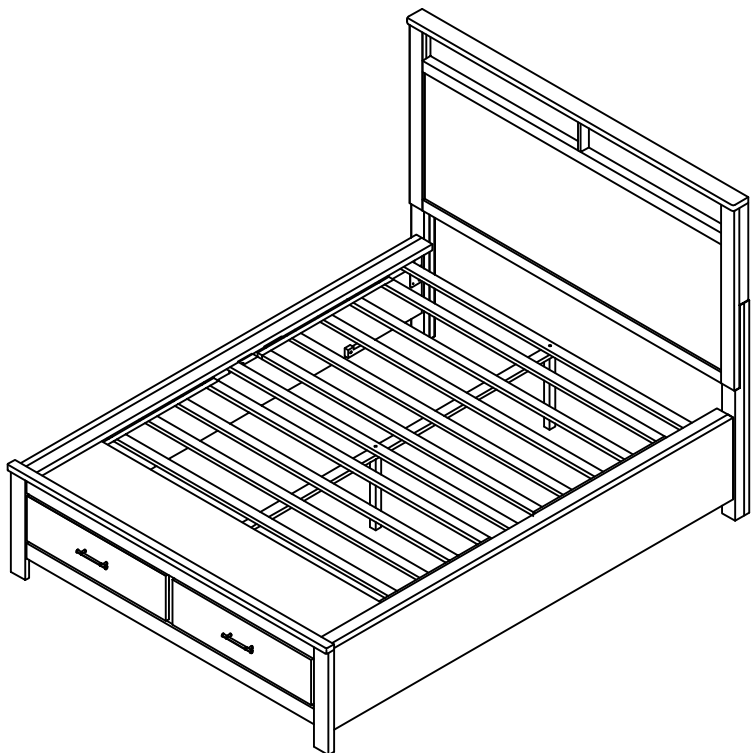

ASSEMBLY IS COMPLETED

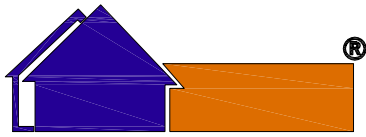

Furniture of America[®]

Assembly Instructions

CM7072EK

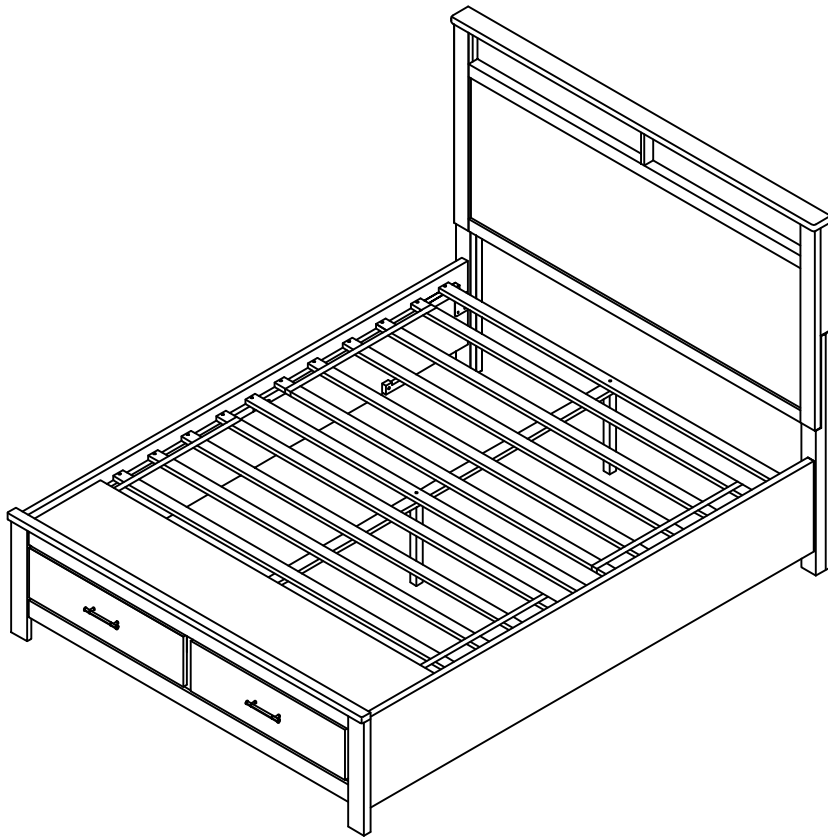

ASSEMBLY RATING

The Assembly Rating is a 5-point system that shows the degree of effort needed in assembling a specific product (with 1 being easy and 5 being difficult). For some products, two persons are recommended.

EASY



DIFFICULT

Tools Required For Assembly:

Allen Wrench

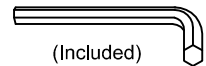

(Included)

Phillips Screwdriver



(Not Included)

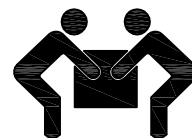

2 PERSONS RECOMMENDED

ASSEMBLY & CARE ADVICE

FOR YOUR FURNITURE TO LAST, CORRECT ASSEMBLY AND PROPER MAINTENANCE ARE NECESSARY. PLEASE FOLLOW THE INFORMATION PROVIDED BELOW TO FULLY ENJOY YOUR FURNITURE.

BASIC ASSEMBLY TECHNIQUES

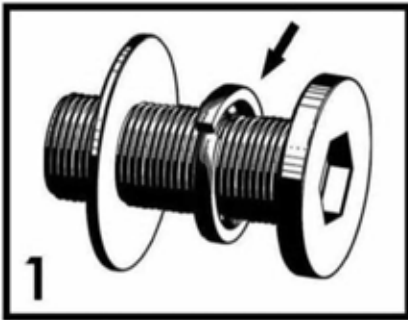

When lock or spring washer is used in an assembly, please make sure the lock or spring washer is placed between the larger flat washer and the head of the screw or bolt.



Position each part correctly and insert screws or bolts into their respective holes by hand tighten or using the proper hand tool. Only tighten when step is completed or when instructed to do so.

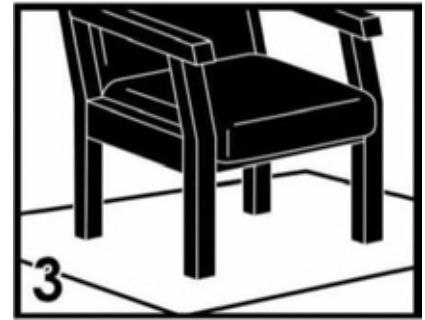

Use cardboard or carpet area when assembling furniture to prevent scratches. Make sure the furniture rests on a flat and level surface with each leg evenly touching the floor.

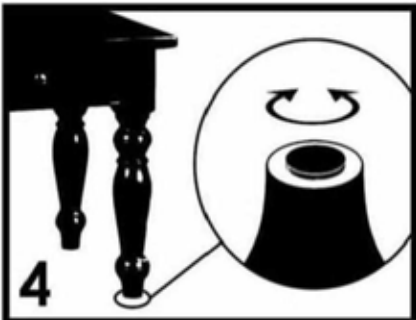

Some furniture comes with height adjustment knobs underneath each leg. To lower or to raise each leg, you need to turn clockwise or counterclockwise, respectively.

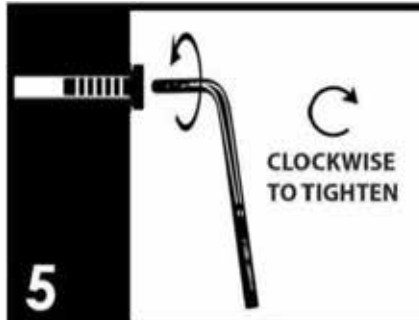

Make sure all parts are properly aligned, then use the appropriate hand tool to completely tighten the bolts or screws. Do not use power tools and do not overtighten.

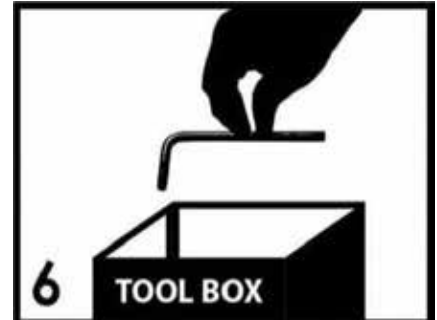

Save the instructions and store the Allen wrench or any supplied tool for later maintenance. After two weeks, check and tighten any loose hardware and repeat again every six months thereafter.

IT IS THE USER'S RESPONSIBILITY TO MAINTAIN THE FURNITURE. THE HARDWARE MAY LOOSEN OVER TIME AND MAY CAUSE THE FURNITURE TO BE WOBBLY AND UNABLE TO SUPPORT ITS INTENDED WEIGHT CAPACITY. THIS MAY LEAD TO COLLAPSE AND MAY CAUSE SERIOUS INJURY.

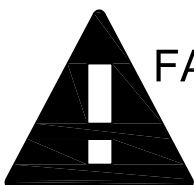

FAILURE TO FOLLOW THE GUIDELINES ABOVE MAY RESULT IN INJURY AND/OR PROPERTY DAMAGE.



Before you begin, please read Page 2 of "Assembly and Care Advice".

And remember, do not tighten until each step is completed or instructed.

Parts List

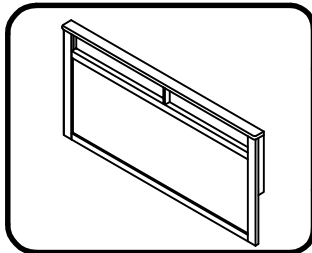

#1 x 1pc
Headboard Panel

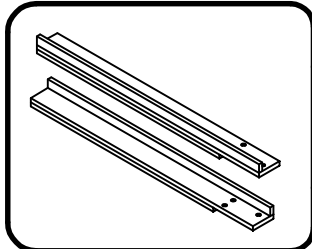

#2 x 2pcs
Headboard Legs L-R

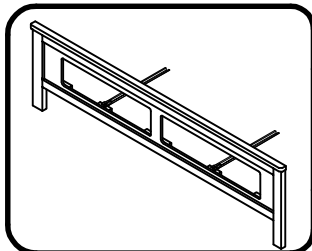

#3 x 1pc
Footboard Panel

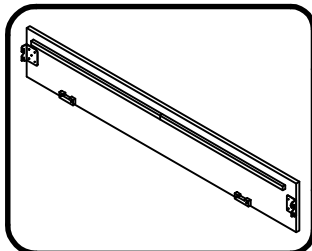

#4 x 2pcs
Side Rail

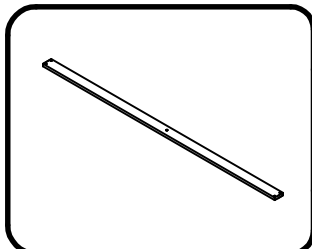

#5 x 1pc
Drawer Slat

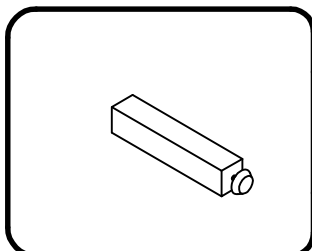

#6 x 1pc
Drawer Slat Support

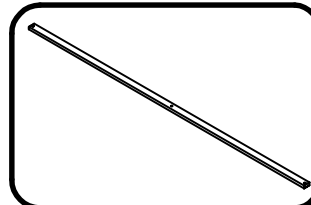

#7 x 3pcs
Bed Slat

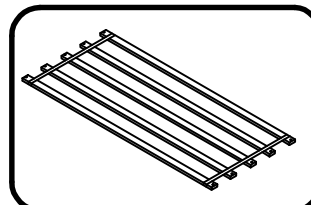

#8 x 2set
Bed Slat (5pcs X2)

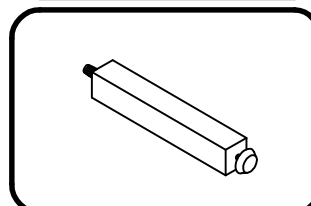

#9 x 3pcs
Slat Support Leg

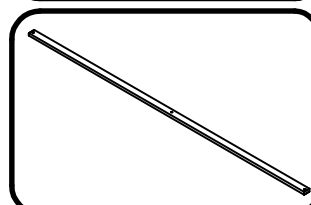

#10 x 1pc
Center Slat

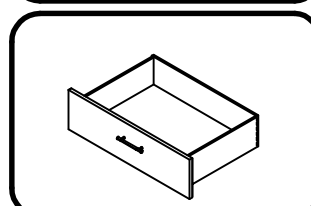

#11 x 2pcs
Drawer Box

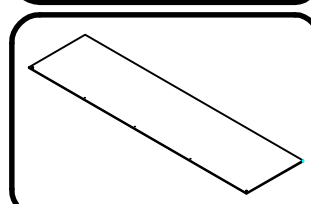

#12 x 1pc
Slat Cover

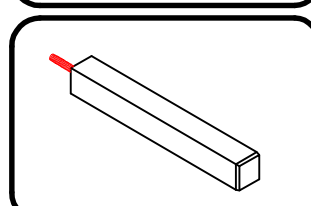

#13 x 1pc
Drawer Slat Support
Stopper



Before you begin, please read Page 2 of "Assembly and Care Advice".

And remember, do not tighten until each step is completed or instructed.

Hardware List



#A x 7pcs
Screw M4 x 5/8"



#E x 6pcs
Flat Washer $\text{\O} \frac{1}{4}$ "

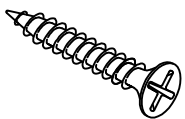

#B x 30pcs
Screw M4 x 1-1/4"



#F x 6pcs
Lock Washer $\text{\O} \frac{1}{4}$ "

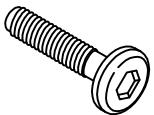

#C x 6pcs
Bolt M6 x 1-3/16"

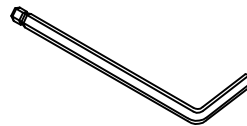

#G x 1pc
Allen Wrench M4

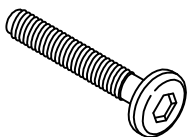

#D x 3pcs
Bolt M6 x 2"

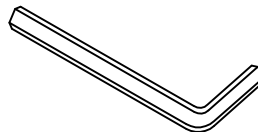

#H x 1pc
Allen Wrench M5



1. Prepare 6 bolt assemblies by first inserting a lock washer (#F) onto the bolt (#C) then a flat washer (#E) onto that same bolt (#C).

#C x 6pcs
#E x 6pcs
#F x 6pcs

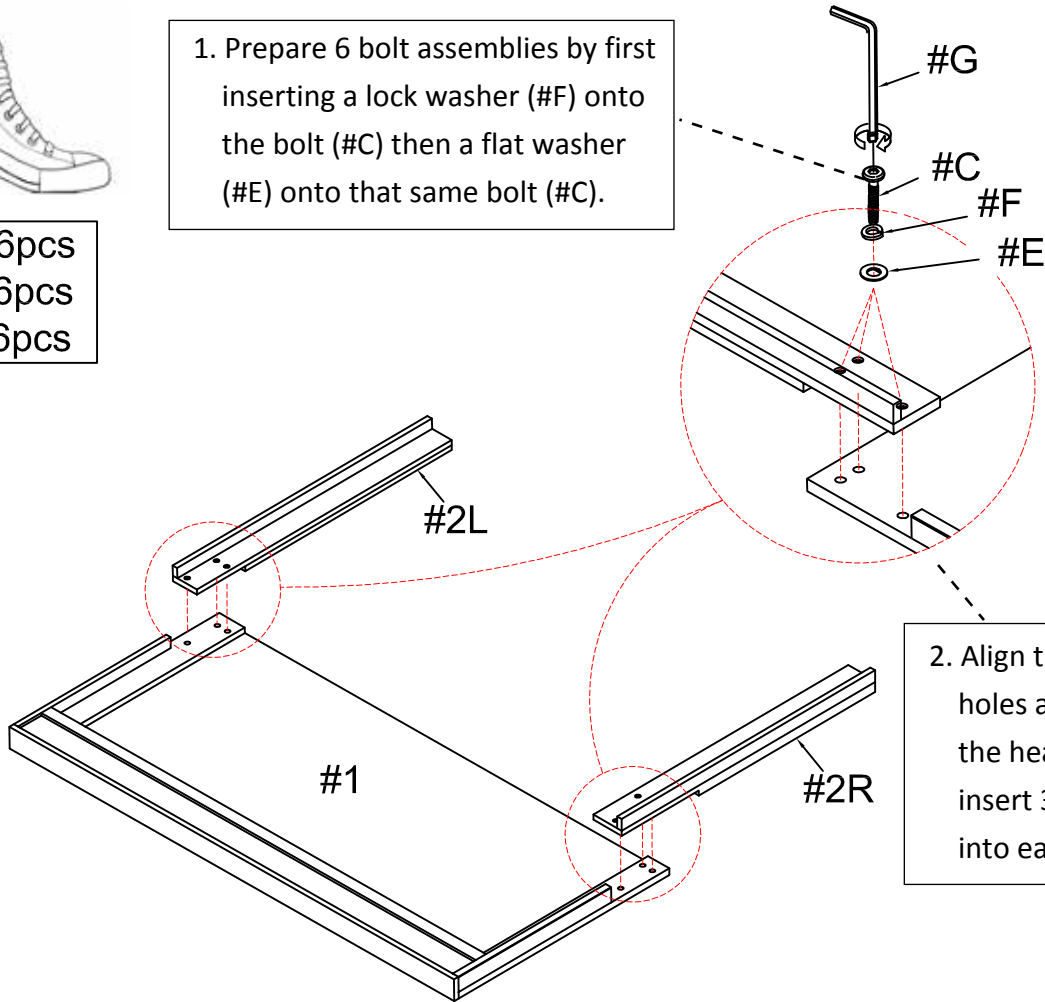

2. Align the legs (#2) to the holes along the back of the headboard (#1), then insert 3 bolt assemblies into each leg and secure.



Hook each end of the side rails (#4) onto the bolts along the headboard (#1) and footboard (#3), then tighten the bolts using the Allen wrench (#H).

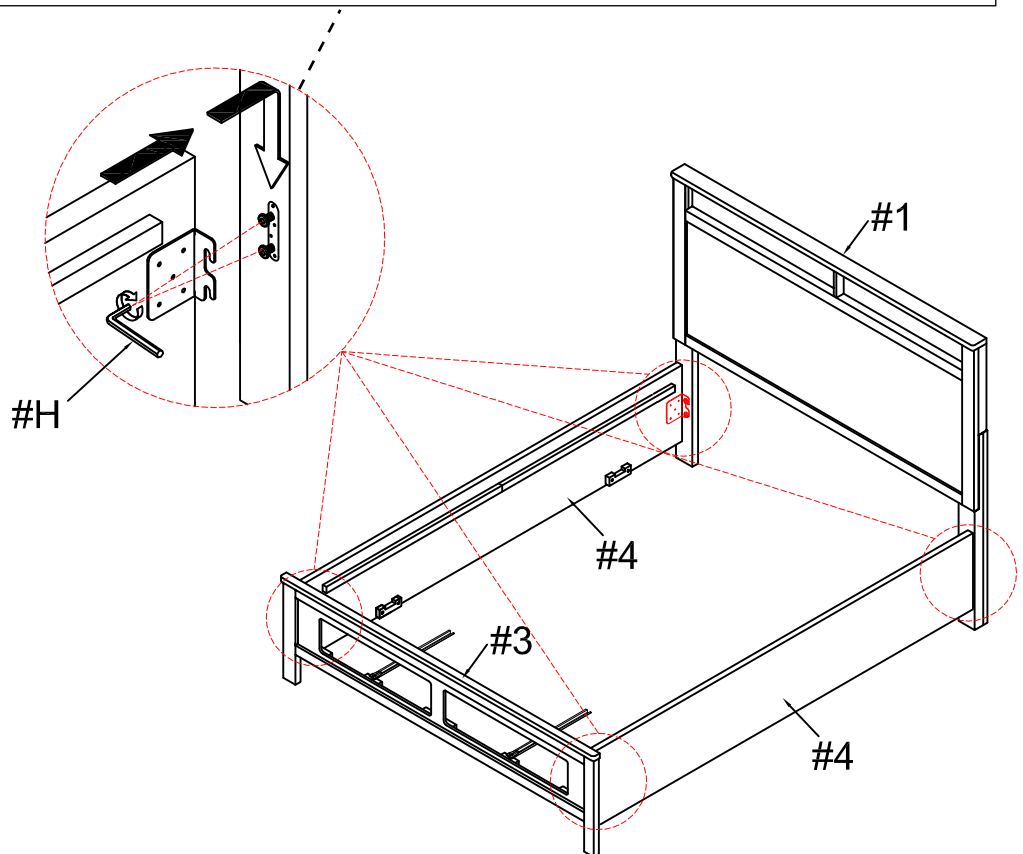



#3

#D x 1pc

Align the drawer slat support (#6) to the hole along the bottom of the drawer slat (#5), then insert the threaded end of the support stopper (#13) into that same hole from above. Turn right to tighten and make sure both supports are firmly secured.

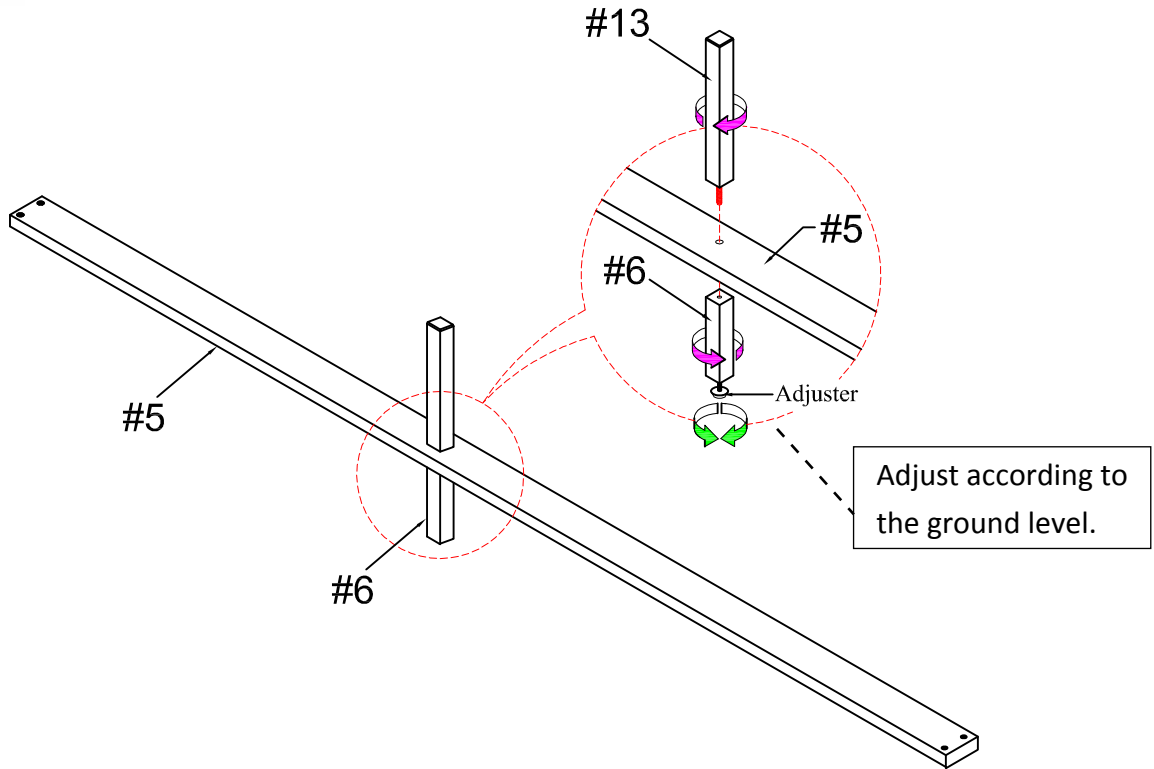

#4

#B x 4pcs

Place the ends of the drawer slat (#5) onto the slots along the rails, then insert 2 screws (#B) into each end. Secure using a screwdriver.

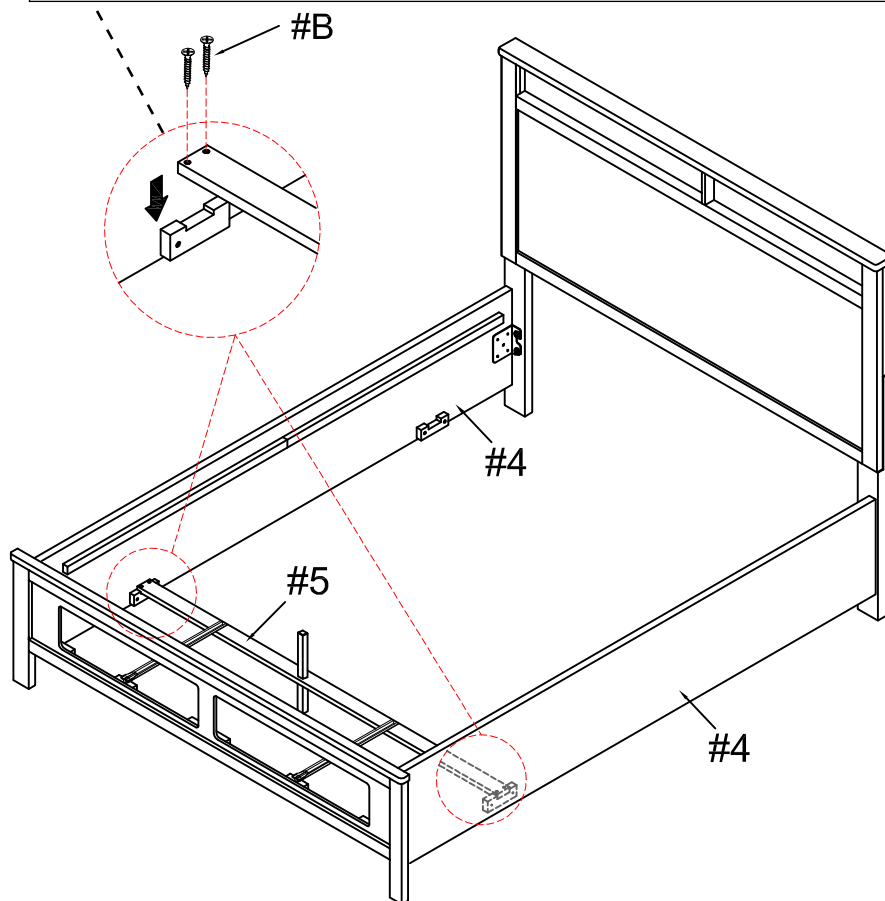



#5

Align the end of the runners to the slat (#5), then insert a screw (#A) into each end. Secure using a screwdriver.

#A x 2pcs

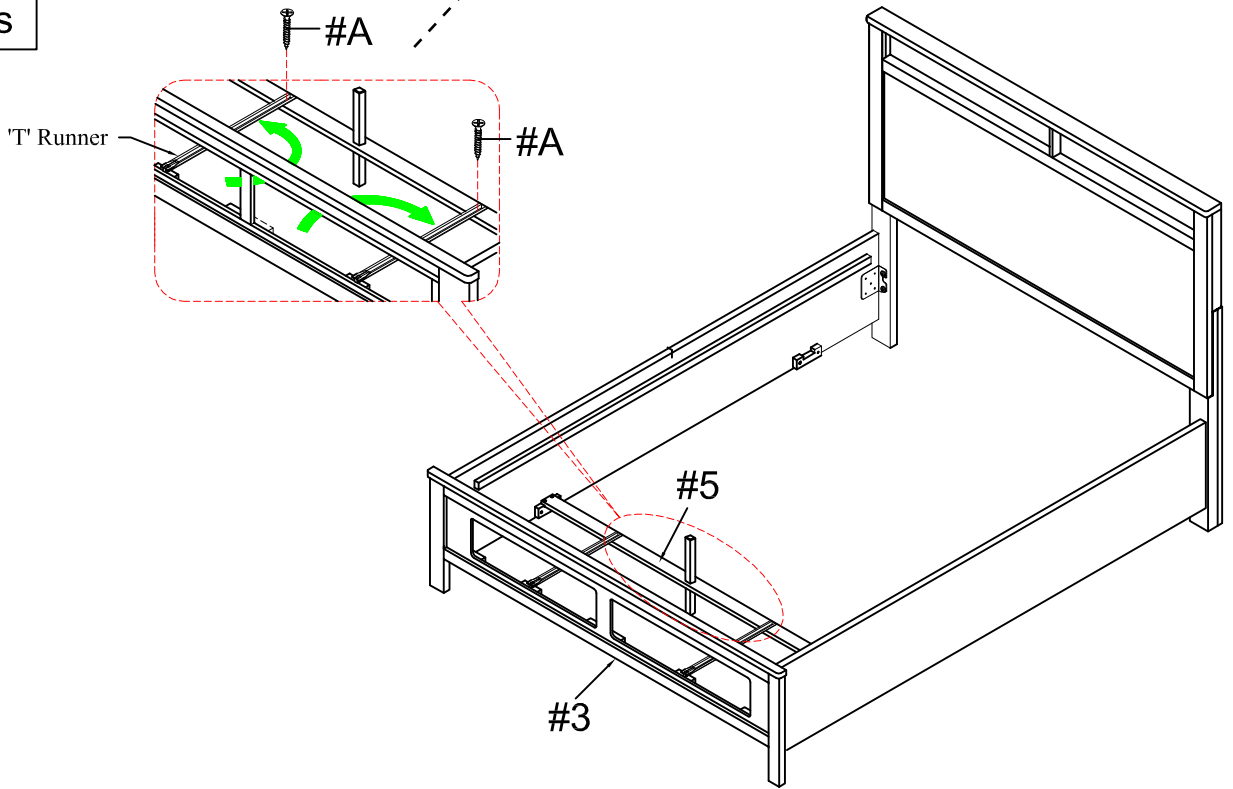

#6

Place the slats (#7) onto the rails, then align the center slat (#10) to the holes along the bottom of those slats (#7) and the slat supports (#9). Insert a bolt (#D) from above and secure.

#D x 3pcs

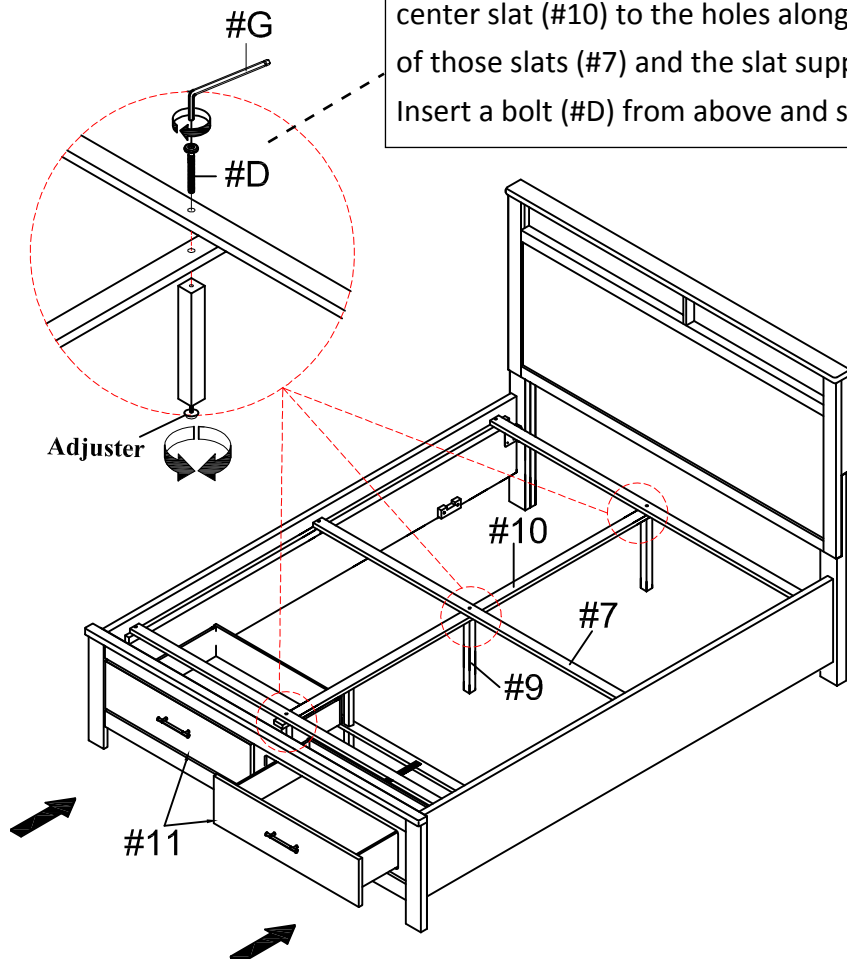



Place the bed slats (#8) onto the rails, then insert a screw (#B) into each end. Secure using a screwdriver.

#B x 26pcs

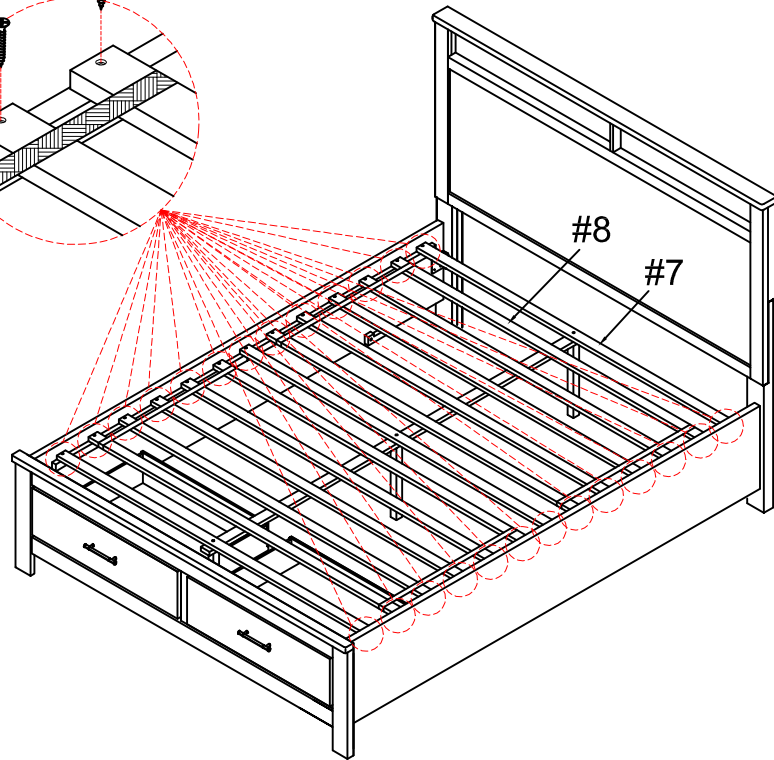
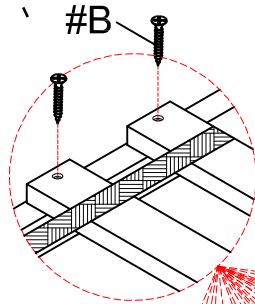

#A x 5pcs

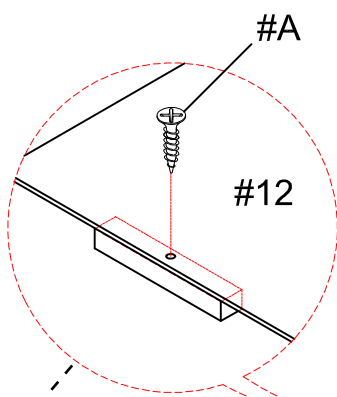

Place the slat cover (#12), then insert the screws (#A) and secure using a screwdriver.

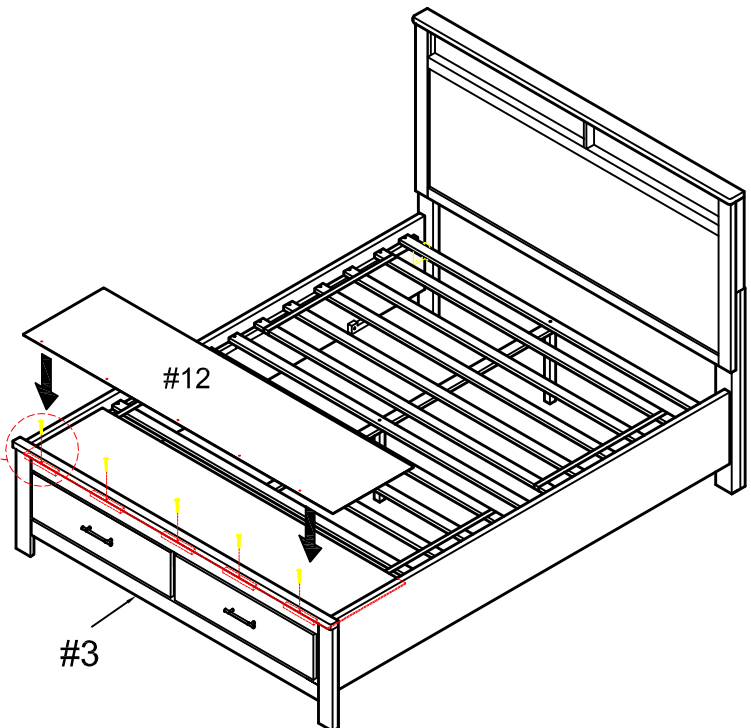

ASSEMBLY IS COMPLETED