

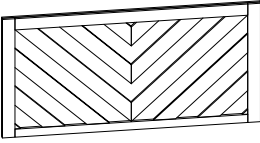

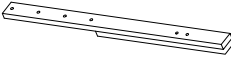

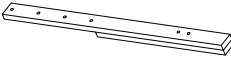

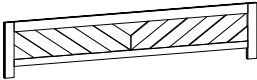
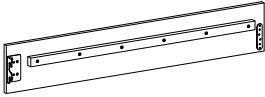
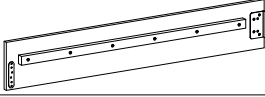
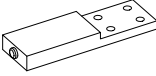

MICAH-GREY - FB/QB ASSEMBLY INSTRUCTION

PART LIST

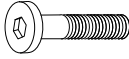
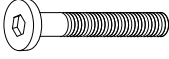
A	HEADBOARD		1 PC
B	HEADBOARD LEG (R)		1 PC
C	HEADBOARD LEG (L)		1 PC
D	FOOTBOARD		1 PC
E	SIDE RAIL (i)		2 PCS
F	SIDE RAIL (ii)		2 PCS
G	SIDE RAIL SUPPORT		2 PCS
H	SLAT		4 PCS
I	CENTER SLAT SUPPORT		4 PCS

HARDWARE LIST

ITEM	DESCRIPTION	DRAWING	QTY
1	JCBB SCREW M8 x 16MM		8 PCS
2	JCBB SCREW M8 x 25MM		8 PCS
3	JCBB SCREW M8 x 40MM		8 PCS
4	SPRING WASHER M8 x 14MM		16 PCS
5	FLAT WASHER M8 x 22MM		16 PCS
6	SCREW M4 x 32MM		8 PCS
7	ALLEN KEY M5		1 PC

MICAH-GREY - FB/QB ASSEMBLY INSTRUCTION

ASSEMBLY TOOLS REQUIRED

1. Screwdriver (not provide)

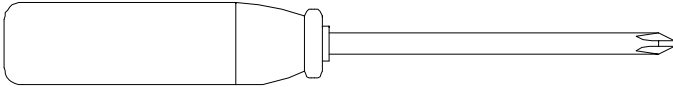

STEP 1

x4

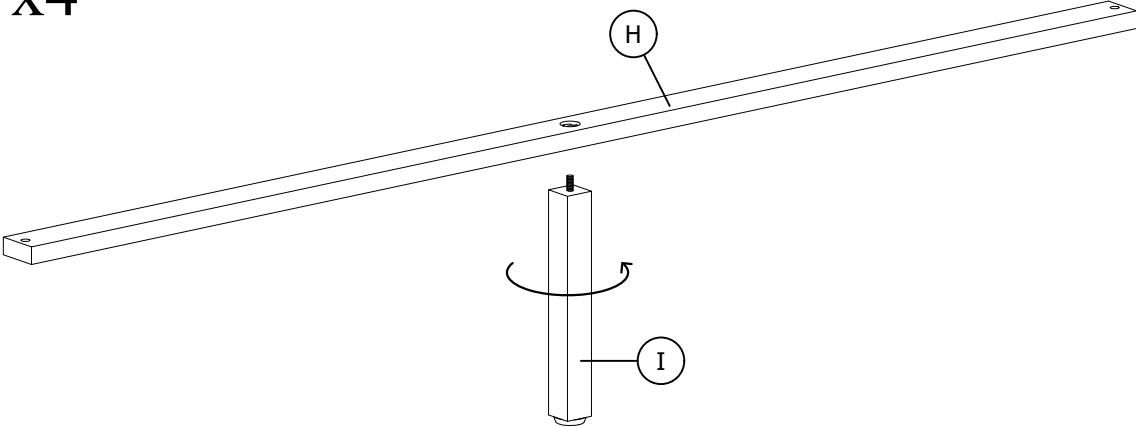

STEP 2

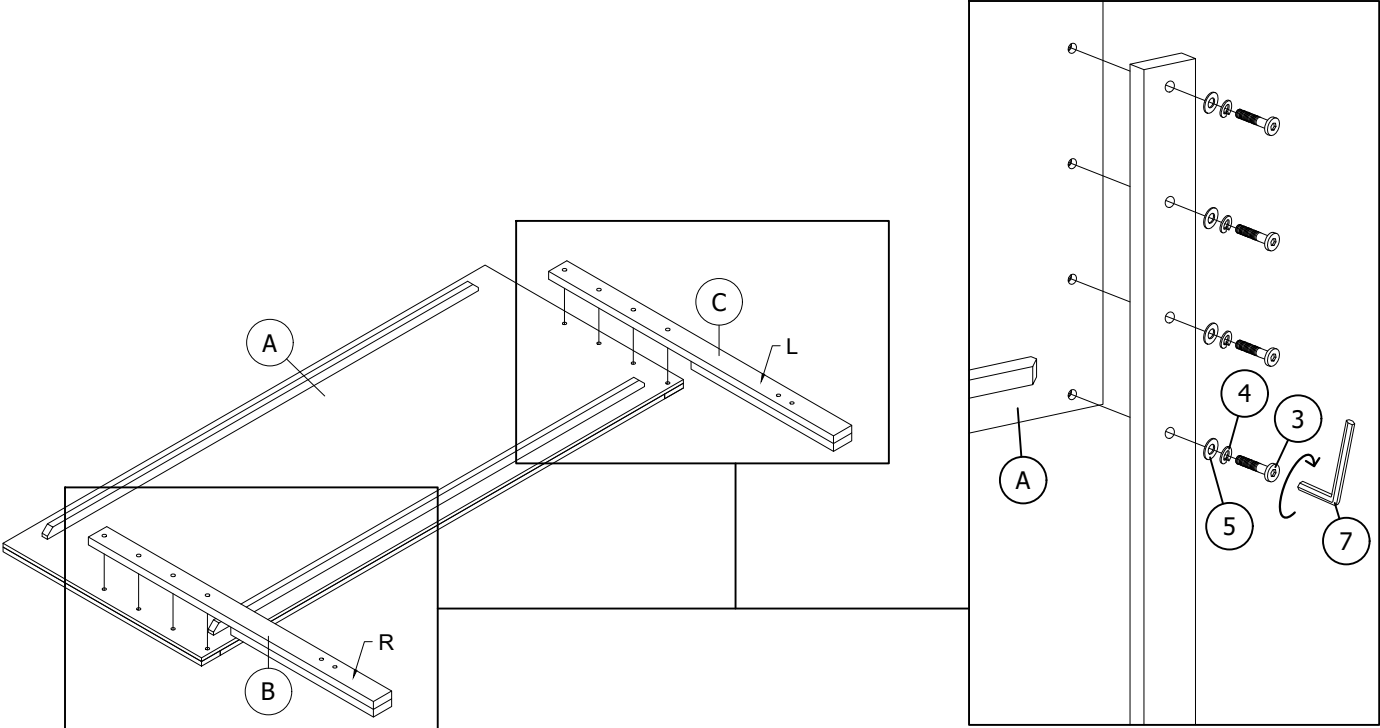

MICAH-GREY - FB/QB ASSEMBLY INSTRUCTION

STEP 3

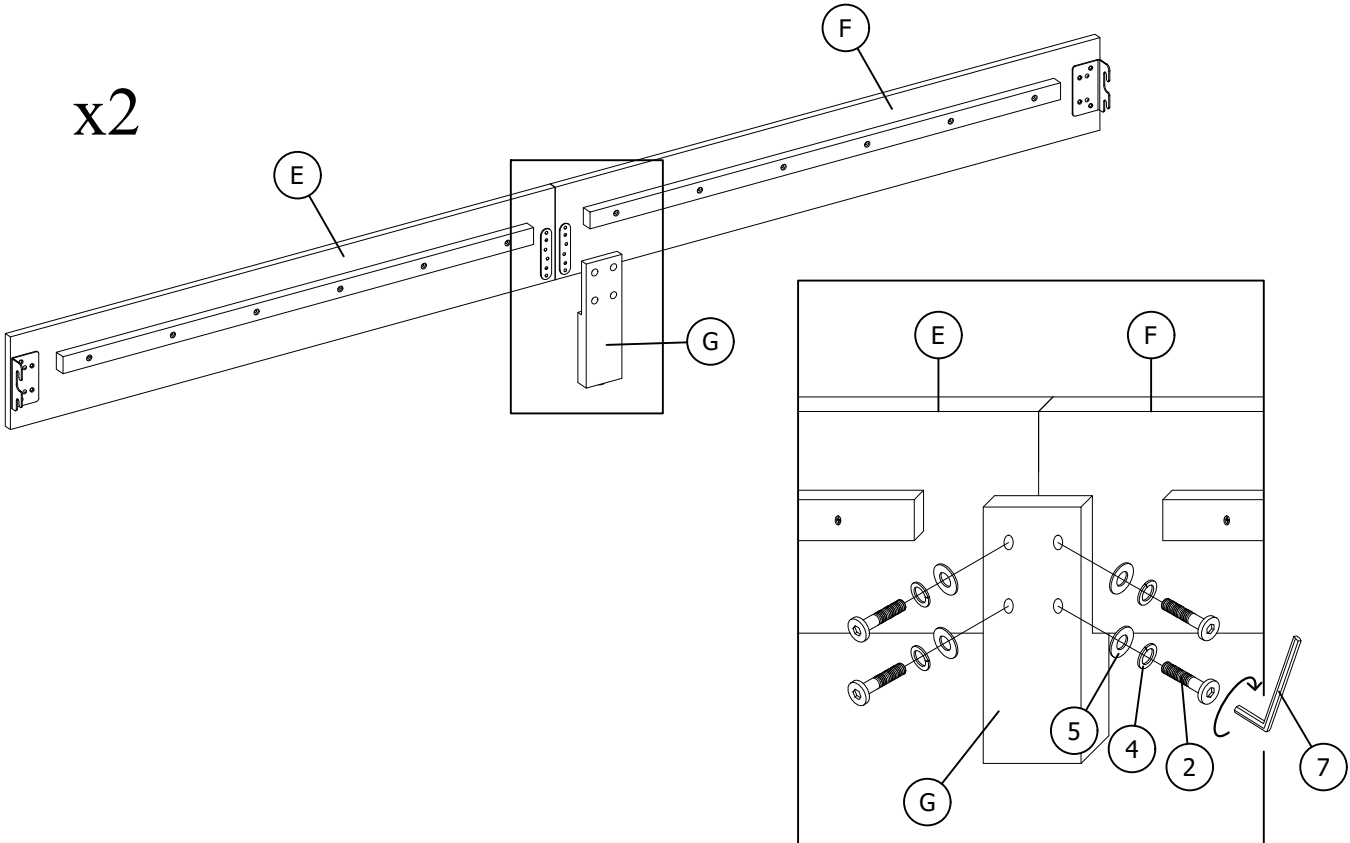

STEP 4

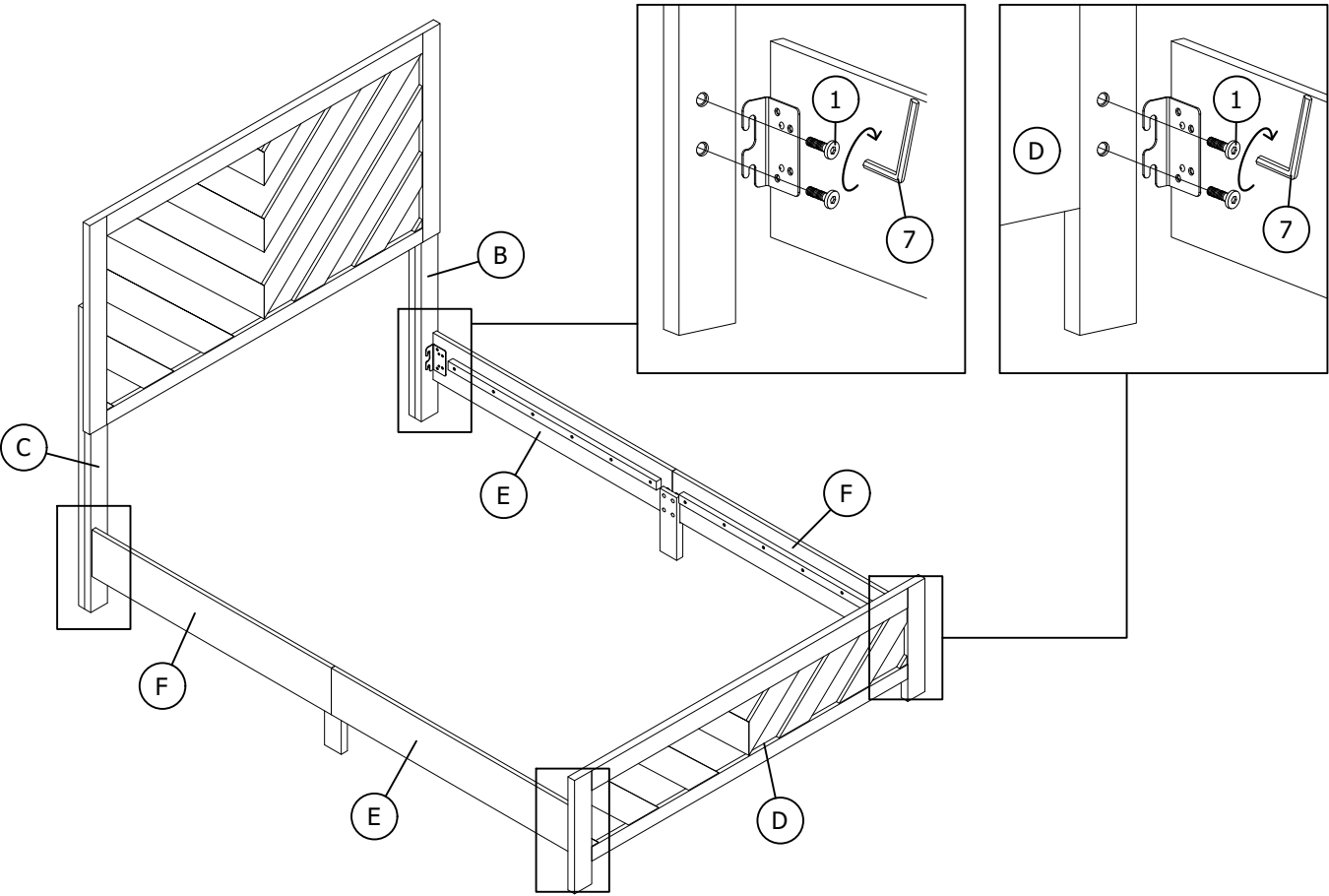

MICAH-GREY - FB/QB ASSEMBLY INSTRUCTION

STEP 5

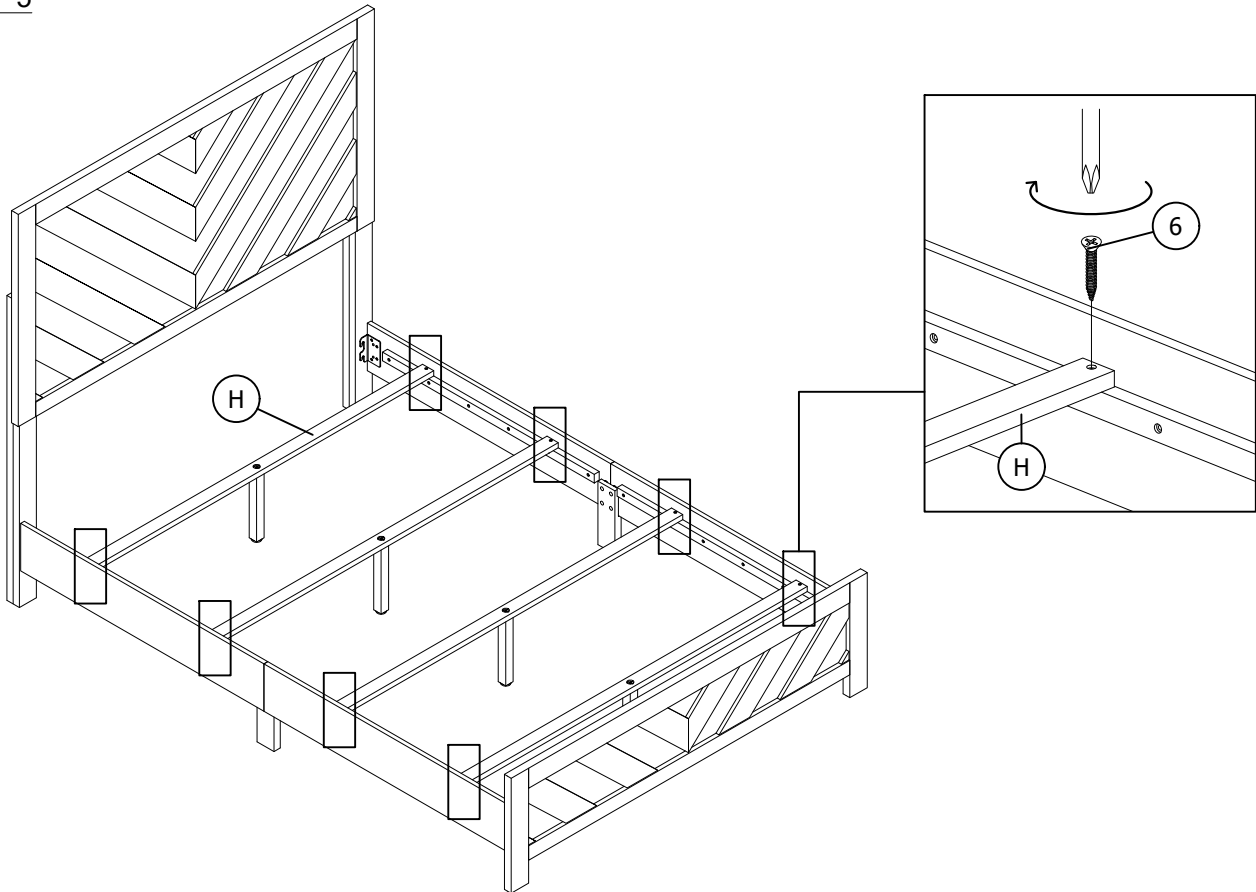

STEP 6

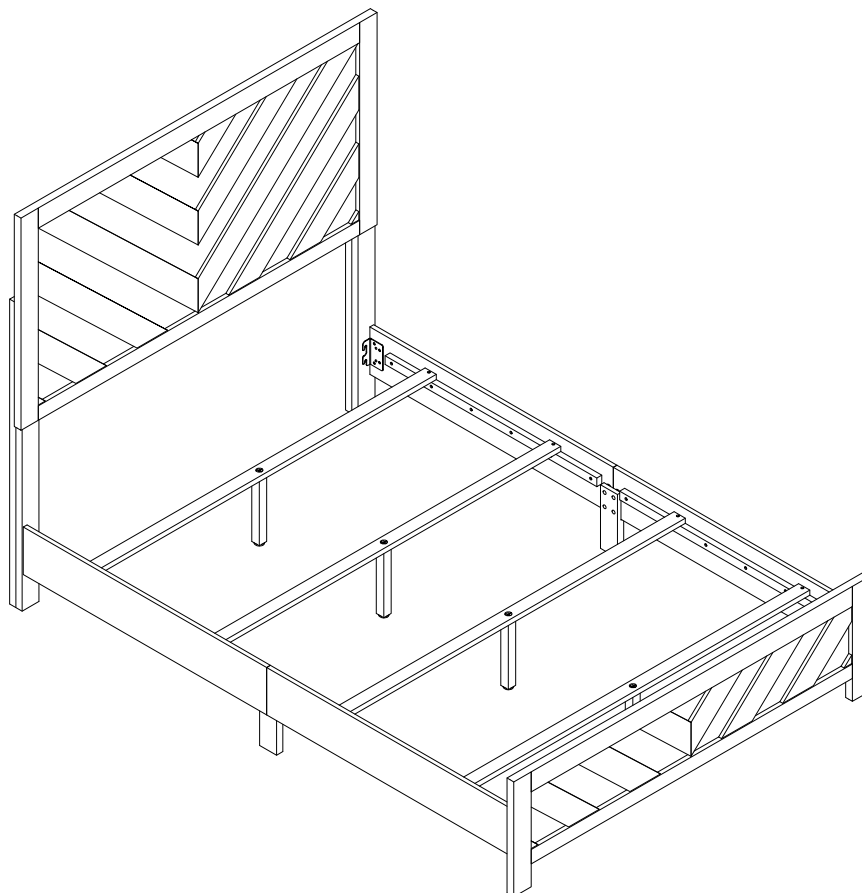

ASSEMBLY COMPLETED