







# ASSEMBLY INSTRUCTION

Model: U2200-PCRLS



Description: POWER CONSOLE RECLINING LOVESEAT

Thank you for purchasing this quality product. Be sure to check all packing material carefully for small parts that may have come loose inside the carton during shipment

## PARTS LIST:

NO.	DESCRIPTION	SKETCH	Q'TY
A	Seat Body		1 PC
B	Left Backrest		1 PC
C	Console Backrest		1 PC
D	Right Backrest		1 PC
E	Left wing		1 PC
F	Right wing		1 PC

## HARDWARE LIST:

NO.	DESCRIPTION	DESCRIPTION	SKETCH	QTY
1	Plug			1 PC
2	Transformer			1 PC
3	Screw with handle	5/16"*50mm		2PCS

### Step 1:

#### Important:

1. Attach the Backrest (B/D) to the Seat (A).
2. Attach the Left/Right Wings (E/F) to the Left/Right side of the Backrest (B/D).

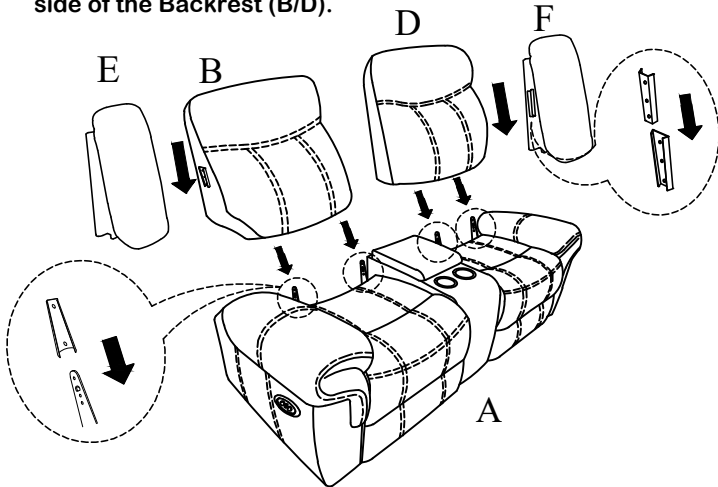

### Step 2:

#### Important:

- Take out the Knob Screws (3) at the Console Backrest (C) then place the Console Backrest (C) to right location and attach to the Seat (A) by turning the Knob Screws (3) clockwise.

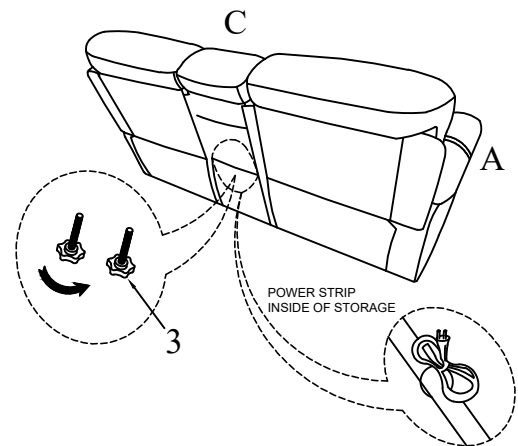

### Step 3: Important:

1. Connect the power wire under the Armrest frame to the power source through out the Transformer (2) and The Plug (1).
2. Open the footrest or move the headrest by pressing the power button on/off.

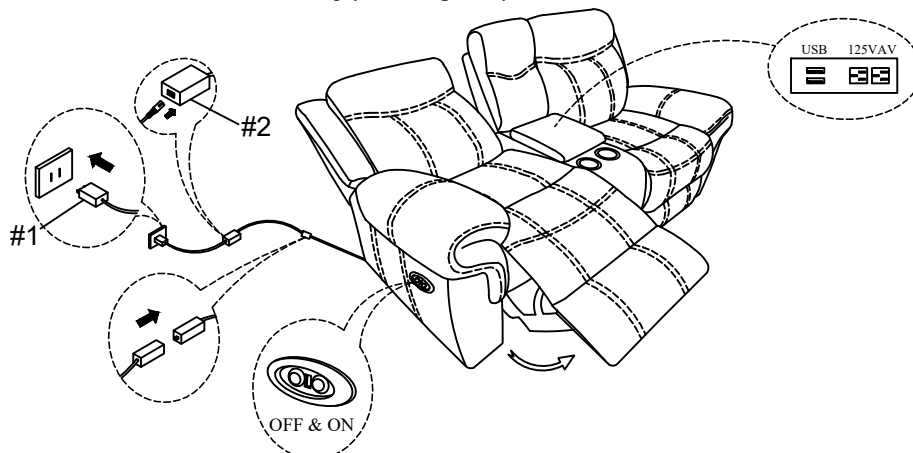

Made in Vietnam





# ASSEMBLY INSTRUCTION

Model: U2200-PR-1



Description: POWER RECLINER

**Thank you for purchasing this quality product. Be sure to check all packing material carefully for small parts that may have come loose inside the carton during shipment**

## PARTS LIST:

NO.	DESCRIPTION	SKETCH	Q'TY
A	Seat Body		1 PC
B	Backrest		1 PC
C	Left wing		1 PC
D	Right wing		1 PC

## HARDWARE LIST:

NO.	DESCRIPTION	DESCRIPTION	SKETCH	QTY
1	Plug			1 PC
2	Transformer			1 PC

### Step 1:

#### Important:

1. Attach the Backrest (B) to the Seat (A).
2. Attach the Left/Right Wings (C/D) to the Left/Right side of the Backrest (B).

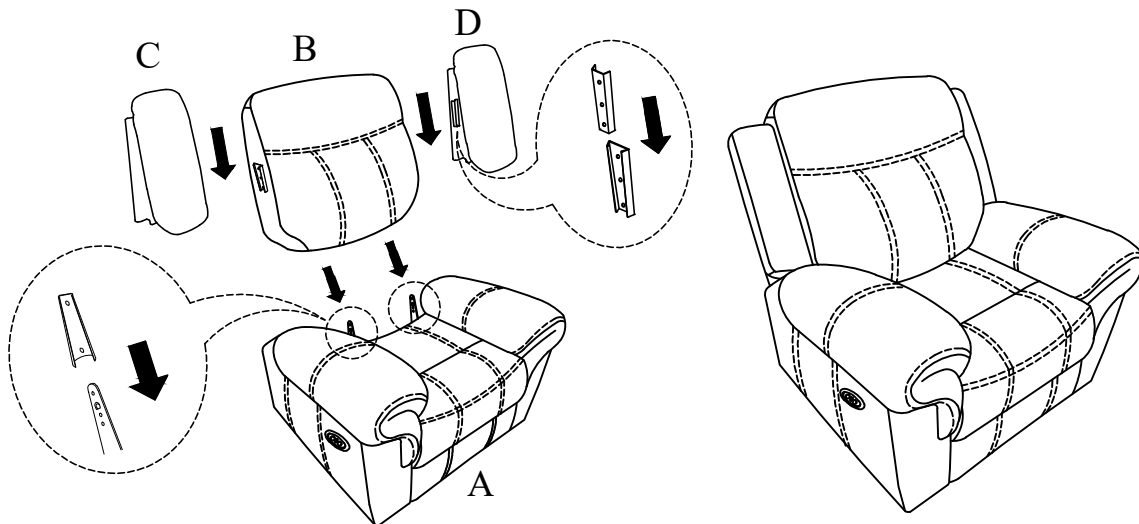

### Step 2:

#### Important:

1. Connect the power wire under the Armrest frame to the power source through out the Transformer (2) and The Plug (1).
2. Open the footrest or move the headrest by pressing the power button on/off.

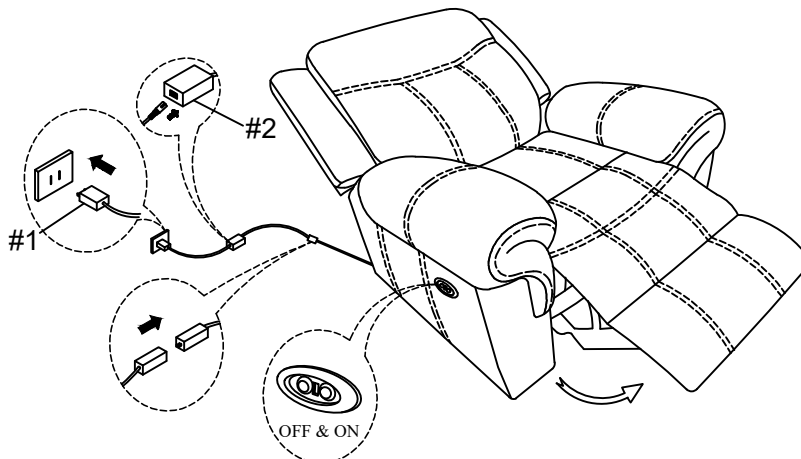







# ASSEMBLY INSTRUCTION

Model: U2200-PRS-1



Description: POWER RECLINING SOFA

Thank you for purchasing this quality product. Be sure to check all packing material carefully for small parts that may have come loose inside the carton during shipment

## PARTS LIST:

NO.	DESCRIPTION	SKETCH	Q'TY
A	Seat Body		1 PC
B	Left Backrest		1 PC
C	Middle Backrest		1 PC
D	Right Backrest		1 PC
E	Left wing		1 PC
F	Right wing		1 PC

## HARDWARE LIST:

NO.	DESCRIPTION	DESCRIPTION	SKETCH	QTY
1	Plug			1 PC
2	Transformer			1 PC

### Step 1:

#### Important:

1. Attach the Backrest (B/C/D) to the Seat (A).
2. Attach the Left/Right Wings (E/F) to the Left/Right side of the Backrest (B/D).

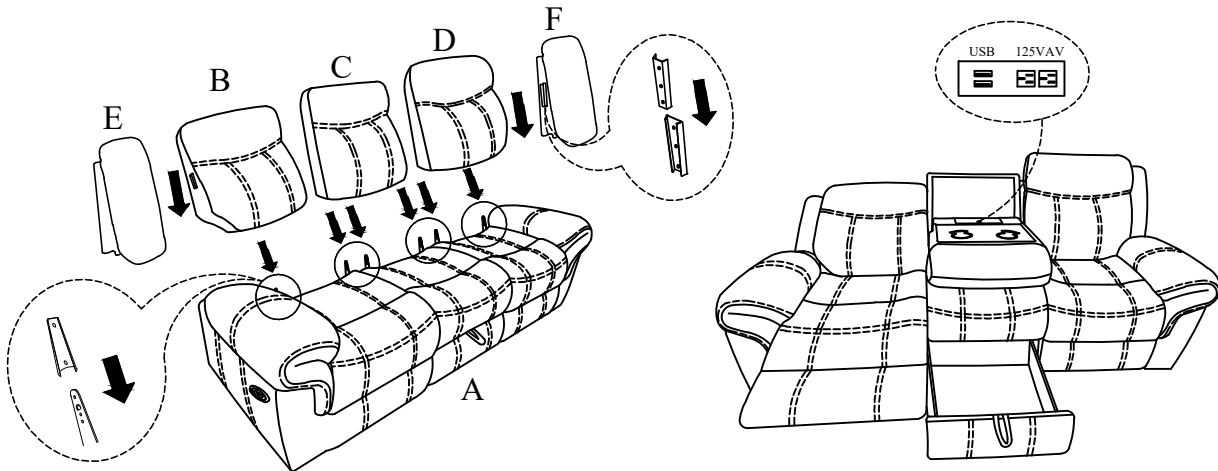

### Step 2: Important:

1. Connect the power wire under the Armrest frame to the power source through out the Transformer (2) and The Plug (1).
2. Open the footrest or move the headrest by pressing the power button on/off.

